

A Study Aid

for the Science of Christian Science

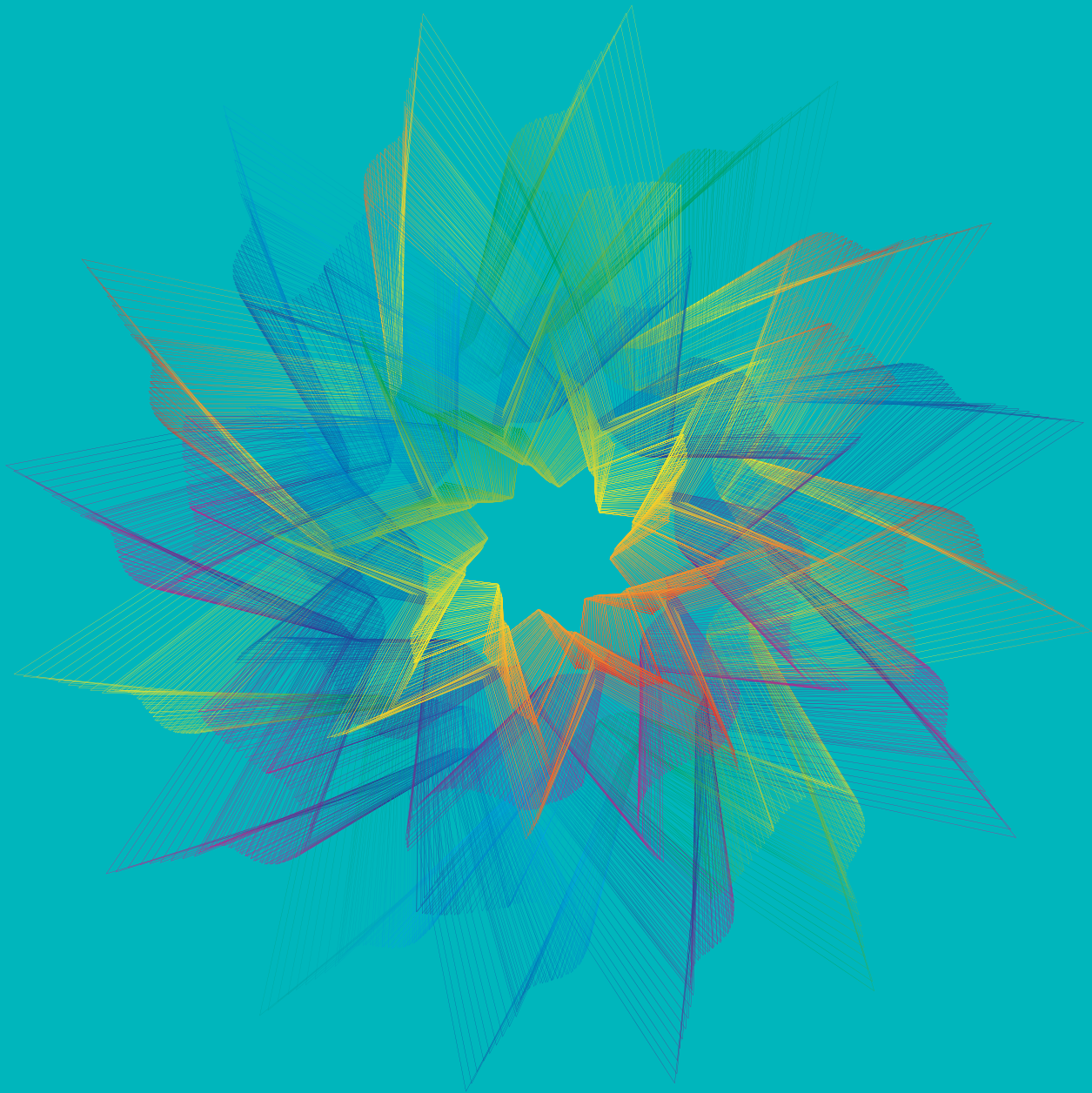

Max Kappeler

**A Study Aid
for the
Science of Christian Science**

Max Kappeler

**Illustrative Material and Diagrams
for Kappeler's Writings and Recordings**



Kappeler Institute Publishing USA
Seattle, WA, USA

A Study Aid for the Science of Christian Science is a compilation of illustrative materials and diagrams collected from over sixty years of Max Kappeler's teaching work. It is most helpful when used in conjunction with his writings and recordings.

This second edition is revised and enlarged.

© 1984 Max Kappeler
© 2020 Kappeler Institute for the Science of Being, second edition
All rights reserved

ISBN 978-0-942958-32-4

Cover by Blueline Design, Seattle WA
Cover image by J.C. Sprott

Kappeler Institute Publishing USA
PO Box 99735, Seattle, WA 98139-0735
Tel: (206) 286-1617
mail@kappelerinstitute.org
www.kappelerinstitute.org

Division of Kappeler Institute for the Science of Being USA
Seattle, WA USA

CONTENTS

NOTE TO READERS: Reference to *A Study Aid* in Kappeler’s books and recordings normally refer to the 1st edition, ©1984. Please use the cross reference below to find the item in this 2nd edition, ©2020.

	Page numbers:	1984	2020
		edition	edition
Preface		i i
 Part I: General Reference Information			
Abbreviations		iii 1
Color Schemes (Doorly, Kappeler, KI USA).....		— 4
Definitions of Scientific Terms		111 5
Science Terminology Worksheet		—	... 12
 Part II: The Divine System of Reference			
The divine system of reference		1	... 21
Eight stages of the development of consciousness		2	... 22
Structure and structural attitude		2	... 22
 Category I: The 7 Synonymous Terms for God: <i>Mind, Spirit, Soul, Principle, Life, Truth, Love</i>			
The Nature of Being		—	... 23
The prism and lens of Science		3	... 25
Rules for studying the 7 synonymous terms for God		4	... 27
The synonymous terms for God and their ideas:			
Mind		6	... 29
Spirit		7	... 30
Soul		8	... 31
Principle		9	... 32
Life		10	... 33
Truth		11	... 34
Love		12	... 35
Understanding and demonstration		13	... 37
The Stages of Culturing Spiritual Consciousness		14	... 38
Mortal Consciousness		15	... 39
The Seven Days of Creation — The First Record of Creation:			
An overall view		16	... 40
With their subtones		17	... 42
The Seven Days of Creation Matrix (29 subtones)		20	... 45
Their fourfold layout		21	... 47
The Second Record of Creation (Adam and Eve story):			
An overall view		22	... 48
With their subtones		23	... 49
Metaphysical comparison between the first and second records of creation ...		26	... 52

	Page numbers:	1984	2020
		edition	edition
The 1000-year periods		28	... 54
Overview of “Genesis” (S&H Chapter XV) in Light of the 7 Synonymous Terms		29	... 56
Numerals of infinity:			
Days of Creation—Numerals of Infinity (S&H 520:10)		30	... 57
The numerals of infinity, called seven days		31	... 59
The 7 synonymous terms for God:			
The blending of ideas		32	... 60
Their sevenfold reflection		33	... 61
Scientific Obstetrics (S&H 463:5–20)		34	... 62
“Animal Magnetism Unmasked”		35	... 63
Healing:			
John Doorly’s method of treatment		36	... 65
The subject of healing in general		36	... 65
“Christian Science Practice”		37	... 66
Category II: The 4-fold Operation of Being: <i>Word, Christ, Christianity, Science</i>			... 67
The Development from the Word to Science		38	... 69
The self-operation of Being		39	... 70
The Four Bible Teachings		40	... 72
The 4 operating as the 7 through divine order		46	... 80
Examples of the Word-order		47	... 83
Word-order — The Law of Creativity		48	... 84
The Christ-translation		49	... 86
The Christ-order		50	... 88
Translation		50	... 88
Ideal ideas		51	... 90
Christ-order—the law of translation and reformation		52	... 91
The development of the Christianity-order		53	... 92
The derivation of the Christianity-order from absolute Christian Science		53	... 92
The inverted Christianity-order		53	... 94
Christianity-order—the law of reflection and demonstration		54	... 95
The triune person—Word, Christ, Christianity		55	... 96
The family law—universal reflection of ideas		55	... 97
Science-order (candlestick)		56	... 98
Science-order—the law of structured understanding		57	...100
Category III: The 4 levels of Science: <i>Science itself, divine Science, absolute Christian Science, Christian Science</i>			...101
The 8 ordered steps from metaphysics to Science		58	...102
Dimensionalism		59	...104
The 4 levels of spiritually scientific consciousness		60	...106
How the levels provide a dimensional analysis of specific issues		61	...107
The 4 levels of Science reflected in Genesis 1:1		62	...108
The Model of Being (“The Chart”) (color)		63	...109

	Page numbers:	1984	2020
		edition	edition
The Survey		64	...111
Word—self-declaration		65	...112
Christ—self-operation		66	...113
Christianity—self-fulfillment		67	...114
Science—self-explanation		68	...116
Divine cybernetic model		69	...117
The dimensional structuring of the ideas of the 7 synonymous terms for God		70	...118
Mind		71	...119
Spirit		72	...120
Soul		73	...121
Principle		74	...122
Life		75	...123
Truth		76	...124
Love		77	...125
Part III: The Laws of Being126
What are the divine laws?		—	...127
The laws of the Model of Being		78	...130
The law of Being		—	...132
The law on the level of Science itself— <i>the law of infinite Being</i>		80	...133
The law on the level of divine Science— <i>the law of divine self-organization</i>		81	...134
The laws on the level of absolute Christian Science— <i>the law of spontaneity</i>		82	...135
The derivation of the laws from the level of Science itself		82	...135
The law of the Word— <i>the law of divine impulsions</i>		83	...136
The law of the Christ— <i>the law of divine individualization</i>		83	...136
The law of Christianity— <i>the law of eternalization</i>		84	...137
The law of Science— <i>the law of prestabilized perfection</i>		84	...137
The laws of interdependence between absolute Christian Science and Christian Science— <i>the law of interdependence in the Word</i>		85	...138
Word:		85	...140
▪ Elaboration through the 4-fold operation		86	...140
▪ Illustrated through the seven days of creation		87	...141
▪ Illustrated through the layout of “St. Matthew”		88	...142
▪ Summary of the layout of “St. Matthew”		91	...146
▪ The translation of “St. Matthew” into Science		92	...148
▪ The formulation of phenomena into a scientific law		92	...148
Christ		93	...150
Christianity		94	...152
Science		95	...153
The Science of the Bible		—	...154
Part IV: Matrices156
The Further Scientific Unfoldment to the Matrix Form		—	...157
Matrix: definition		96	...159
The One Book—The Word		—	...161

	Page numbers:	1984	2020
		edition	edition
John Doorly's Matrix (Word-matrix)		97	...162
The sixth day of creation: The diagonal of the Doorly-matrix		98	...163
The sixth day diagonal: The tones of the synonyms		99	...164
The Christ-matrix		100	...165
The Christianity-matrix		101	...166
The Matrix of Christian Science (<i>Textbook-matrix</i>)		102	...167
i-Matrix		103	...169
j-Matrix		104	...170
The Matrix of the Oneness of Being		105	...171
The Platform		106	...173
Ideas Dissolve Beliefs— <i>Chapter X, "Science of Being" in Science and Health</i> ...		—	...174
Mind Matrix		107	...175
Super Matrix		108	...176
The Spiritual Principle of Prayer		109	...177
The Matrix of Handling Evil		110	...178

PREFACE

The fundamental insight—that Christian Science is a *Science*—brings with it critical implications for how Christian Science can be approached scientifically. Whereas religion draws on sentiment, belief, and ritual observance, a science requires an ordered, systematic education with inquiry into fundamental divine categories and laws of Being.

An ordered schooling is fundamental to the Science of Christian Science. Why? The essence of Science lies in its ability to reduce the infinite One—namely, God as a whole—to the simplicity of a few fundamental divine categories of Being. What are these divine categories as found in *Science and Health with Key to the Scriptures* by Mary Baker Eddy? These divine categories of Being are as follows:

- 1) The 7 synonymous terms for God—Mind, Spirit, Soul, Principle, Life, Truth, Love—present the *nature* of Being.
- 2) The 4-fold calculus—Word, Christ, Christianity, Science—shows the *self-operation* of Being.
- 3) The 4 levels of Science—Science itself, divine Science, absolute Christian Science, Christian Science—show the *dimensions of spiritual consciousness* thorough which Being operates and presents itself in life-experience.

Through these few divine categories, the nature, operation and multidimensional workings of the one Being can be understood, revealing the divine system of Science. As Mrs. Eddy stated:

“Divine metaphysics is now reduced to a system, to a form comprehensible by and adapted to the thought of the age in which we live” (S&H 146:31). MH: Reduction to system.

The system of the fundamental categories of Being (7+4+4) presents the basic tools of Christian Science. All scientific work—be it study and research, text-interpretation, or demonstration and practice—builds on an understanding of these categories.

“This system enables the learner to demonstrate the divine Principle on which Jesus’ healing was based” (S&H 147:1).

The system of Science provides the foundation for all understanding and demonstration, establishing in us a divine standpoint and consciousness.

To this end, study and research in the Science of Christian Science is devoted wholly to understanding the few fundamental categories, focusing on such questions as:

- How are the *capitalized terms for God* (7+4+4) defined divinely (rather than in a humanly subjective way)?
- What *scientific methods* enable us to discover their divine definition?
- How do the 7+4+4 *blend and interrelate* with each other, not only to correct counterfeit concepts, but also to *form a spiritual structure*?

- How do these spiritual structures manifest themselves in the Bible, the Textbook (*Science and Health*), and the Model of Being?
- How do the spiritual structures (7+4+4) enable us to discern the *spiritual laws* of Being?

The information and diagrams in this *Study Aid* have evolved over years in the ongoing endeavor to answer these questions through Science and a spiritually scientific understanding of the Bible and the Christian Science textbook. Experience has shown that visual aids, especially in the form of charts or diagrams, are highly supportive of a more structured understanding of the subject. Unlike prose, charts and diagrams are uniquely adapted presenting—with maximum simplicity—a whole structure of relationships. They thereby convey the core of the subject, providing a basis for much elaboration and individual inspiration. For this reason, I have brought together, in this book, those few diagrams which are most adapted to explaining the scientific system of Christian Science—though this collection is by no means exhaustive.

On each page of this *Study Aid* are references showing where, in my many books and recordings, the subject is explained in depth. In this way, the *Study Aid* can be of great assistance to individual home-study. One finds a line of ordered investigation of the subject through which each student can progress self-reliantly in the study of the Science of Christian Science.

Because this *Study Aid* mainly contains diagrams and not the explanation that goes along with them, it should only be used in conjunction with my books and summer school recordings. It is not intended to stand as a self-contained presentation of the subject.



Max Kappeler
Spring 1984

PART I

General Reference
Information

ABBREVIATIONS **used in Kappeler's works**

The following abbreviations are used throughout Kappeler's writings and recordings:

The divine system of reference (the 7+4+4)

The 7 Synonymous Terms for God

M	=	Mind
Sp	=	Spirit
So	=	Soul
P	=	Principle
Li	=	Life
T	=	Truth
Lo	=	Love

The 4-fold Operation of Being

W	=	Word
X	=	Christ
Xty	=	Christianity
Sc	=	Science

The 4 Levels of Science

Sc	=	Science itself
dSc	=	divine Science
aCS	=	absolute Christian Science
CS	=	Christian Science

The synonym-orders (on the level of Christian Science)

W-o	=	Word-order M, Sp, So, P, Li, T, Lo
X-o	=	Christ-order P, Li, T, Lo, So, Sp, M
Xty-o	=	Christianity-order P; M; So; Sp; Li; T; Lo
Sc-o	=	Science-order P / So-Li, Sp-T, M-Lo / P

The Model of Being

MOB	=	the Model of Being (Kappeler)
Chart	=	the Chart (Doorly)

c. of	=	counterfeit of
vs.	=	versus

The works of Mary Baker Eddy (MBE)

S&H	=	<i>Science and Health with Key to the Scriptures</i>
<i>Science and Health</i>	=	<i>Science and Health with Key to the Scriptures</i>
the Textbook	=	<i>Science and Health with Key to the Scriptures</i>

The works of Mary Baker Eddy (MBE) – continued–

- '00 = *Message to the Mother Church*, June 1900
- '01 = *Message to the Mother Church*, June 1901
- '02 = *Message to the Mother Church*, June 1902
- Chr. = *Christ and Christmas*
- C&C = *Christ and Christmas*
- Hea. = *Christian Healing*
- Man. = *Manual of the Mother Church*
- MH = marginal heading within *Science and Health*
- Mis. = *Miscellaneous Writings*
- My. = *The First Church of Christ, Scientist, and Miscellany*
- No. = *No and Yes*
- Peo. = *The People's Idea of God*
- Pul. = *Pulpit and Press*
- Ret. = *Retrospection and Introspection*
- Rud. = *Rudimental Divine Science*
- Un. = *Unity of God*

Works about Mary Baker Eddy by other authors

- Mis. Doc. = *Miscellaneous Documents Relating to Christian Science and its Discoverer and Founder Mary Baker Eddy* (Published by G. Carpenter, 1961)

The Works of John W. Doorly (JWD)

- Bible-talks = *Talks on the Science of the Bible* (there are two editions, “red” and “blue”)
- Oxford-talks = *Talks at the Oxford Summer School*
- Statement = *A Statement by John W. Doorly*

Books by Max Kappeler

- A. M. book = *Animal Magnetism—Unmasked*
- Bible-books = *The Bible in the Light of Christian Science*, Vols. I–IV
- compendium = *Complete Compendium for the Study of Christian Science* (#1–10)
- development-book = *The Development of the Christian Science Idea and Practice*
- epistle-book = *The Epistles in the Light of Christian Science*
- epitome-book = *Epitomes for the Spiritually Structured Interpretation of the Christian Science Textbook*
- government = *Christian Science Government*
- introduction-book = *Introduction to the Science of Christian Science*
- level-book = *The Four Levels of Spiritual Consciousness*
- oneness-book = *The Science of the Oneness of Being in the Christian Science Textbook*
- prophet-book = *The Minor Prophets in the Light of Christian Science*
- study aid = *A Study Aid for the Science of Christian Science*
- structure-book = *The Structure of the Christian Science Textbook—Our Way of Life*
- synonym-book = *The Seven Synonyms for God*

Recordings by Max Kappeler

Tape Codes = Each recording has been assigned a specific tape code, which is listed before the title. For example: A-6III, *Syllabus III*. Also, each audio hour is divided into two sections, A and B (originally these were the “sides” on 60 or 90 minute cassettes). For example: A-6III #5B is the 5th lecture hour, second half.

Books of the Bible

Acts	=	The Acts of the Apostles
Col.	=	The Epistle of Paul the Apostle to the Colossians
I Cor.	=	I Corinthians
II Cor.	=	The Second Epistle of Paul the Apostle to the Corinthians
Dan.	=	The Book of Daniel
Deut.	=	The Fifth Book of Moses, called Deuteronomy
Eph.	=	The Epistle of Paul the Apostle to the Ephesians
Ex.	=	The Second Book of Moses, called Exodus
Gal.	=	The Epistle of Paul the Apostle to the Galatians
Gen.	=	The First Book of Moses, called Genesis
Hab.	=	Habakkuk
Heb.	=	The Epistle of Paul the Apostle to the Hebrews
Isa.	=	The Book of the Prophet Isaiah
James	=	The General Epistle of James
Jer.	=	The Book of the Prophet Jeremiah
Job	=	The Book of Job
Josh.	=	The Book of Joshua
John	=	The Gospel According to St. John
I John	=	The First Epistle General of John
I Kings	=	The First Book of The Kings
Luke	=	The Gospel According to St. Luke
Matt.	=	The Gospel According to St. Matthew
Mark	=	The Gospel According to St. Mark
Rom.	=	The Epistle of Paul the Apostle to the Romans
II Pet.	=	II Peter
Phil.	=	Philippians
Pro.	=	The Proverbs
Ps.	=	The Book of Psalms
Rev.	=	The Revelation of St. John the Divine

COLOR SCHEMES

Below are the color schemes used by Doorly, Brook, Kappeler, and KI USA. Although the colors used for the 7 synonyms is randomly chosen (you may select any color scheme for your own notes), the colors for the 4-fold operation of Being and 4 levels of Science are derived from the colors selected for Principle, Life, Truth, and Love. Please note this when devising your own color scheme.

John W. Doorly / Peggy Brook

7 Synonyms for God

Mind	red
Spirit	orange
Soul	yellow
Principle	black
Life	green
Truth	blue
Love	purple

Max Kappeler

7 Synonyms for God

Mind	black
Spirit	red
Soul	yellow
Principle	purple
Life	brown
Truth	blue
Love	green

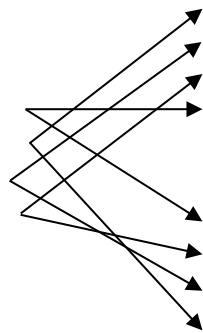

4-fold Operation of Being

Word	(Life)
Christ	(Truth)
Christianity	(Love)
Science	(divine Principle, Love)

4 Levels of Science

Science itself	(infinite Principle)
divine Science	(Love)
absolute Christian Science	(Truth)
Christian Science	(Life)

Kappeler Institute USA Publications (based on the rainbow/prism)

7 Synonyms for God

Mind	red
Spirit	orange
Soul	yellow
Principle	green
Life	blue
Truth	indigo
Love	violet

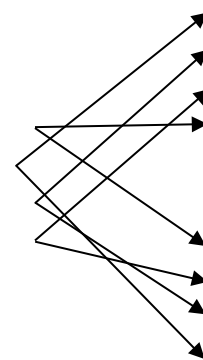

4-fold Operation of Being

Word	(Life)
Christ	(Truth)
Christianity	(Love)
Science	(divine Principle, Love)

4 Levels of Science

Science itself	(infinite Principle)
divine Science	(Love)
absolute Christian Science	(Truth)
Christian Science	(Life)

DEFINITIONS of scientific terms

See also: *The Pure Science of Christian Science*, John W. Doorly, pp. 91–93.

calculus

A process of reasoning by the use of symbols (Webster).

Calculus of operations: A systematic method of treating problems by operating upon (seeing the relationship among) symbols of operation (Webster).

vs. *combinatorics*: random combining.

References:

Books by John W. Doorly:

Christian Science Practice, John W. Doorly, pp. 308–309.

Talks on the Science of the Bible, Vol. I (red-book), pp. 41–43.

Talks on the Science of the Bible, #60 (blue-book), pp. 4–11, 31–32.

category

One of the underlying forms to which any fact known by experience must conform; specifically defined divisions in a system of classification (Webster).

A class, division, genus, family, or type with which distinctions are made among things for conceptual analysis and classification (Peter A. Angeles: Dictionary of Philosophy).

Any basic idea, concept, notion, or principle fundamental to a system of philosophy; an ultimate conceptional form by which knowledge is made possible, providing the foundation for all meaning (*ibid.*)

A system of categories is constituted of the pure concepts or principles that provide the necessary structure for understanding. Nothing is intelligible unless put into the framework of these categories. Our understanding of things is formed by the categories. And things themselves are formed by the forces acting in nature which operate according to these categories (*ibid.*).

References:

Books by Max Kappeler:

'*Stately Science Pauses Not*' (booklet), pp. 16–24.

Books by John W. Doorly:

Talks on the Science of the Bible, #63 (blue-book), pp. 3–5, 5–13 (as presented in 'The Apocalypse').

Recordings by Max Kappeler:

A-6V: *Syllabus V*, hour #1.

C-1AP: *CH. XVI, The Apocalypse, The Structure of the Christian Science Textbook—Our Way of Life*, hours #1–2.

classification

Systematic arrangement in groups or categories according to established criteria (Webster).

cybernetics

Kybernetes (Gk.): 'steersman,' 'pilot,' 'controller,' 'governor.'

The study of systems that are self-regulating, self-controlling, and self-operating through a feedback mechanism which exercises adaptive control.

References:

Books by Max Kappeler:

A Study Aid for the Science of Christian Science, Page 117: “Divine Cybernetic Model”
The Four Levels of Spiritual Consciousness, p. 49.

Recordings by Max Kappeler:

B-2: *From Atomistic Thinking to Cybernetic Comprehensive Consciousness*, hour 20B.

D-2: *Divine Cybernetics: The proto-science, the integral Science*, hours #1–6, #11B (this class goes on to explain “The Model of Being” in the light of the cybernetic concept in hours #7–20).

G-2: *The Science of Being—As I See It Today*, hours #7B–8.

X-15: *Divine Cybernetics*.

dimensionalism

The concept that one identity, when translated to different levels or standpoints of consciousness, can appear in different forms, while at the same time preserving its one, original identity (see *A Study Aid for the Science of Christian Science*, page 104).

gestalt

A unified physical, psychological, or symbolic configuration having properties that cannot be derived from its parts (American Heritage Dictionary).

The basic idea is that the parts of a shape only have meaning by the fact that they belong to a whole, i.e., a shape cannot be split up into its elements without losing the meaning which it possess as a whole. A form is more than the sum-total of its elements (Francois, Charles (editor), *International Encyclopedia of Cybernetics and Systems*, KG. Saur, Munich, Germany, 1997).

References:

Books by Max Kappeler:

The Science of the Oneness of Being in the Christian Science Textbook, pp. 52, 175–176.

holism

The view that an integrated whole has a reality independent of and greater than the sum of its parts (Webster).

The thesis that wholes, or some wholes, are more than the sums of their parts in the sense that the wholes in question have characteristics that cannot be explained in terms of the properties and relations to one another of their constituents (Harper Dictionary of Modern Thought).

holistic explanation: 1. Explaining phenomena in terms of the functions (purposes, properties, activities) of a whole (form, totality, unity) that is the guiding principle of its parts. 2. Explaining the activity of the parts of a whole in terms of the functions of that whole (Angeles, Peter A., *Dictionary of Philosophy*, Harper Collins, NY, 1981).

References:

Books by Max Kappeler:

The Science of the Oneness of Being in the Christian Science Textbook, pp. 23–25, 52–53, 169–176, 179–180.

Books by John W. Doorly:

Talks on the Science of the Bible, Vol. III (red-book), pp. 375–376.

interpretation

root: *inter* = between

pretari = to show, explain, point out (Century Dictionary)

a) *unscientific meaning:*

1. To explain what is inexplicit.
 - to explain what is unintelligible
 - explanation of what is not immediately plain or explicit (Webster)
 - to interpret the hidden meaning of a parable (Random House)
2. Individually subjective.
 - to understand and appreciate in the light of individual belief, judgment, interest, or circumstance (Webster)
 - to perform or render according to one's understanding or sensibility (Random House)
3. Translation.
 - translation from one language into another (Webster)
4. To interpret by representation.
 - to apprehend and represent by means of art, e.g., to show by illustrative representation (Webster)

b) *scientific meaning:*

1. Explanation through general principles.
 - explanation of actions, events, or statements by pointing out inner relationships ... or by relating particulars to general principles (Webster)
 - a matter of accentuation according to the context or frame of reference defined by the structure
 - "knowing this first that no prophecy of the scriptures is of only private interpretation. For the prophecy came not in old time by the will of man: by holy men of God spake as they were moved by the Holy Ghost" (II Peter 1:20, 21)
 - To leave "to mortals' interpretation ... to identify the meaning is susceptible of abuse owing to one's ignorance.... The only safety ... must lie in confining (the interpretation) to generalities and not specialties" (Oakes, Richard F., (editor), *Essays and other Footprints, of Mary Baker Eddy*, Rustica Press, South Africa, 1959, p. 63)

vs. *interpolate*: To alter or corrupt by inserting new or foreign matter; especially to change, as a book or a text, by inserting matter that is new or foreign to the purpose of the author (Webster).

References:

Books by Max Kappeler:

The Bible in the Light of Christian Science, Vol. I: Genesis, pp. 1–19.

Complete Compendium for the Study of Christian Science, Appendix 11, The Study of Ideas (p. 399), (showing how a knowledge of the system of ideas enables us to detect the tones of the subjects in the chapter).

Epitomes for the Spiritually Structured Interpretation of the Christian Science Textbook, pp. 1–11.

The Four Levels of Spiritual Consciousness, pp. 25–28.

Introduction to the Science of Christian Science, pp. 146–163, 168.

Only Science Reveals (booklet), pp. 1–4, 12–15, 23–25.

The Seven Synonyms for God, chapter 10.

'*Stately Science Pauses Not*' (booklet), pp. 24–27.

Books by John W. Doorly:

Talks at the Oxford Summer School, 1948, Vol. I, pp. 89–90.

Recordings by Max Kappeler:

C-1C: *CH. IX, Creation, The Structure of the Christian Science Textbook—Our Way of Life*, hours #3, #5–7A.

C-2PR: *CH. I, Prayer, The Christian Science Textbook: A workshop on text-interpretation*, hours #24–25.

law

A general statement describing an invariable order or regularity that exists under certain specific conditions (Dictionary of Philosophy).

References:

Books by Max Kappeler:

Animal Magnetism – Unmasked, pp. 147–156, 191–192.

The Science of the Oneness of Being in the Christian Science Textbook, pp. 57–59.

Introduction to the Science of Christian Science, pp. 168–169.

The Minor Prophets in the Light of Christian Science, pp. 26–27, 40–41, 208–209.

Recordings by Max Kappeler:

E-1: *The Structure of Being and its Universal Laws*, hour #6B.

matrix

See page 156.

References:

Books by Max Kappeler:

The Science of the Oneness of Being in the Christian Science Textbook, pp. 225–256.

The Minor Prophets in the Light of Christian Science, pp. 17–19.

Recordings by Max Kappeler:

C-4: *The Matrix of Science and Health: An overview*, hour #6.

C-6: *Exercises in Culturing Consciousness According to the Matrix of Science and Health*, hours #1B–2A.

E-2: *The Matrix of Immortality: Code of divine laws*, hours #1–4A, #20.

G-2: *The Science of Being—As I See It Today*, hours #4–7.

order

Regular arrangement; any methodical or established succession or harmonious relation; method; system; A condition in which everything is so arranged as to play its proper part; as, “order is heaven’s first law”—Alexander Pope (Webster).

Sequence, disposition; the fixed arrangement formed in the existing constitution of things; a natural, moral or spiritual system in which things proceed to definite laws (Oxford).

The sequence or arrangement of things or events, series, succession; a fixed or definite plan, system or law of arrangement; (rhetoric) the placing of words in such a manner as to contribute ... to the clear illustration of the subject (Webster).

References:

Books by Max Kappeler:

‘*Stately Science Pauses Not*’ (booklet), pp. 14–16.

Books by John W. Doorly:

Christian Science Practice, pp. 21–22.

Talks at the Oxford Summer School, 1948, Vol. I, pp. 143–144, 232–233.

Talks on the Science of the Bible, Vol. I (red-book), p. 109.

Talks on the Science of the Bible, #70 (blue-book), pp. 15–16.

Talks on the Science of the Bible, #71 (blue-book), pp. 5–9.

The Pure Science of Christian Science, pp. 92–93.

paradigm

A world view or model of understanding and consciousness.

A universally recognized scientific achievement that for a time provides model problems and solutions to a community of practitioners (Thomas Kuhn, *The Structure of Scientific Revolution*).

Some accepted examples of actual scientific practice — examples which include law, theory, application, and instrumentation together — which provide models from which spring particularly coherent traditions of scientific research (*ibid.*).

References:

Recordings by Max Kappeler:

E-1: *The Structure of Being and its Universal Laws*, hours #1–4.

science

Knowledge of a single fact, not known as related to any other, or of many facts not known as having any mutual relations or as comprehended under any general law, does not reach the meaning of science: science is knowledge reduced to law and embodied in a system (Funk & Wagnalls Dictionary).

A branch of study which is concerned either with a connected body of demonstrated truths or with observed facts systematically classified and more or less colligated by being brought under general laws, and which includes trustworthy methods for the discovery of new truths within its own domain (Oxford Dictionary).

“Divinely defined, Science is the atmosphere of God; humanly construed, and according to Webster, it is ‘knowledge, duly arranged and referred to general truths and principles on which it is founded, and from which it is derived.’ I employ this awe-filled word in both a divine and human sense” (No. 9:25).

References:

Books by Max Kappeler:

Complete Compendium for the Study of Christian Science, #1, Introduction, p. 1.

Introduction to the Science of Christian Science, pp. 141–145.

The Four Levels of Spiritual Consciousness, pp. 24–25.

The Science of the Oneness of Being in the Christian Science Textbook, pp. 31–34.

‘*Stately Science Pauses Not*’ (booklet), pp. 6–8, 28.

Why Study Christian Science as a Science? (booklet), pp. 5–11.

Books by John W. Doorly:

The Pure Science of Christian Science, p. 92.

Recordings by Max Kappeler:

C-1PR: *CH. I, Prayer, The Structure of the Christian Science Textbook—Our Way of Life*, hours #1–3.

D-4: *Divine Cybernetics and the Self-operating “Dimensional Laws” of the One Being, God*, hour #1.

M-17: *Why Study Christian Science as a Science?*

structure

Root: *structura* (Latin) = to arrange, to fit together, ordering.

The interrelationships of parts as dominated by the general character of the whole (Webster).

Structures appear wherever elements combine into a meaningful whole whose arrangements follow definite laws (Webster).

A structure is the sum-total of relationships which maintains the communication among the various parts of a whole (Amar).

structuralism

- A method of procedure which transforms every problem into a structural problem (Amar).
- In structuralism, an object itself and its various constituents are seen as points of intersection of multitudinous systems of reference (*ibid.*).
- Structuralism is a mode of thought; structuralism constitutes essentially a method. By method [is meant] any set of rules or regulations which describes and prescribes the operations to be performed upon any matter with the purpose of ordering it and understanding its workings (Michael Lane, *Introduction to Structuralism*).
- A structure is a system of transformations. Inasmuch as it is a system and not a mere collection of elements and their properties, these transformations involve laws: the structure is preserved for enriched by the interplay of its transformation laws, which never yield results external to the system nor employ elements that are external to it. In short, the notion of structure is comprised of three key ideas: the idea of wholeness, the idea of transformation, and the idea of self-regulation (Jean Piaget, *Structuralism*).

References:

Books by Max Kappeler:

Introduction to the Science of Christian Science, pp. 151–152.

The Science of the Oneness of Being in the Christian Science Textbook, pp. 52–53.

'Stately Science Pauses Not,' (booklet), pp. 9–12, 31.

Recordings by Max Kappeler:

D-4: *Divine Cybernetics and the Self-operating "Dimensional Laws" of the One Being, God*, hour #1.

E-1: *The Structure of Being and its Universal Laws*, hours #4–6.

G-2: *The Science of Being—As I See It Today*, hours #4–5.

synergy

The additional benefit accruing to a number of systems should they coalesce to form a larger system; the concept reflects the classical idea that the whole is greater than the sum of its parts. Synergy is formally studied as property of systems by cybernetics (Harper Dictionary of Modern Thought).

References:

Books by Max Kappeler:

The Science of the Oneness of Being in the Christian Science Textbook, pp. 23–25, 175–176

synonymous

By synonymous words we usually understand words that coincide or nearly coincide in some part of their meaning, and may, hence, within certain limits be used interchangeably, while outside of these limits they may differ very greatly in meaning and use. It is the office of a work on synonyms to point out these correspondences and differences, that language may have the flexibility that comes from freedom of selection within the common limits, with the perspicuity and precision that result from exact choice of the fittest word to express each shade of meaning outside of the common limits. To consider synonymous words identical is fatal to accuracy; to forget that they are similar, to some extent equivalent and sometimes interchangeable, is destructive of freedom and variety (Funk & Wagnalls).

Thus, synonymous terms: (a) coincide in some part of their meaning and are in this context — in this certain limit — freely interchangeable; yet also (b) have clearly distinguishable differences and are, therefore, not freely interchangeable outside of context (a).

vs. *equinym*s: Words identical or completely equivalent in meaning (many linguists maintain that no such words exist, for, in the economy of language, why would there be two rather than one word, if indeed there were no perceivable difference?).

References:

Books by Max Kappeler:

Introduction to the Science of Christian Science, pp. 30–32.

The Seven Synonyms for God, Chapter 1.

'*Stately Science Pauses Not*,' (booklet), pp. 18–20

Why Study Christian Science as a Science? (booklet), pp. 14–15.

Books by John W. Doorly:

A Statement by John W. Doorly, p. 17.

The Pure Science of Christian Science, pp. 19–20, 91.

Recordings by Max Kappeler:

A-1: *An Introduction to the Science of Christian Science*, hours #2–3A.

A-5: *A Seminar on the 7 Synonymous Terms for God*, hours #1B–2.

A-6II: *Syllabus II*, hours #1B–2A.

D-4: *Divine Cybernetics and the Self-operating "Dimensional Laws" of the One Being, God*, hour #2A.

system

A regularly interacting or interdependent group of items forming a unified whole (Webster).

An assemblage of things unified into a consistent whole by a regular inter-relationship (interaction, interdependence, interconnection) of its parts (Angeles, Peter A., *Dictionary of Philosophy*, Harper Collins, NY, 1981).

An assemblage of things working in a coherent order according to some rational or intelligible principle, plan or method (*ibid.*).

The principle or method of operation by which the consistent and coherent order of the whole is achieved and/or explained (*ibid.*).

References:

Books by Max Kappeler:

Complete Compendium for the Study of Christian Science, "System" pp. 7–9.

'*Stately Science Pauses Not*,' (booklet), pp. 18–20.

Books by John W. Doorly:

A Statement by John W. Doorly, pp. 16–24.

The Pure Science of Christian Science, p. 92.

SCIENCE TERMINOLOGY WORKSHEET

The terms below are important to an understanding of Science. Use this worksheet to write in definitions and refer back to them as you study.

TERM	DEFINITION
3 fundamental categories	
4 levels of Science	
4 modes of operation	
7 synonymous terms	
15 root-notions	
1000-year periods in biblical history	
absolute Christian Science	
All-in-all	
animal magnetism	
ascending way	
descending way	

Being / being	
being-building	
calculus	
capitalized terms for God	
City Foursquare	
Christ	
Christ-matrix	
Christ-consciousness	
Christ-idea	
Christ-impulsion	
Christ-operation	
Christ-order	
Christ-translation	
Christianity	

Christianity-matrix	
Christianity-order	
Christian Science	
Christian Science practice	
concept-building	
consciousness-building	
divine metaphysics	
divine Mind-reading	
divine Science	
epitome	
error	
false concepts/attitudes	
4 levels of Science/ spiritual consciousness	
4-fold calculus	

4-fold operation of Being	
Holy City	
idea(s)	
infinite calculus	
law of oneness	
Life	
Love	
man	
manhood	
material sense(s)	
matrix of Being, “matrix of immortality”	
mental anatomy	
mental malpractice	
mesmerism	

metaphysics	
Mind	
Model of Being	
mortal mind	
mortal thoughts	
oneness	
oneness of Being	
personal sense	
Principle	
re-translation	
Science of Christian Science	
Science of Being	
Science-matrix	
Science itself	

Science-level	
Science-order	
scientific obstetrics	
sense-testimony	
sevenfold order	
sin	
Spirit	
spiritualism, spiritism	
Soul	
subtone	
synonym-consciousness	
synonymy principle	
system of reference	
the Textbook	

tonality	
tonality-building	
tone	
translation	
Truth	
understanding (and demonstration)	
womanhood	
Word	
Word-order	

Additional Definitions

Additional Definitions – cont.

NOTES:

PART II

The Divine System
of Reference

THE DIVINE SYSTEM OF REFERENCE

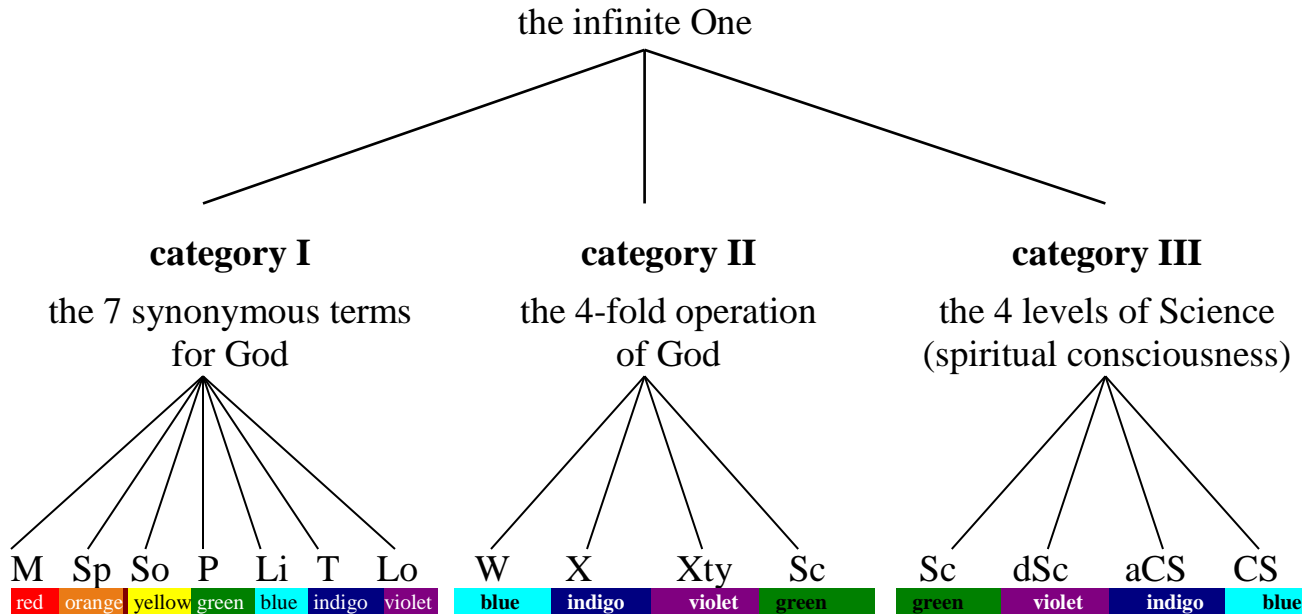

Science: The key of Science lies in its ability to reduce the infinite One to simplicity:

- a) to a few, simple, fundamental yet comprehensive categories
- b) that interrelate and operate with each other on one Principle to form dynamic and coherent structures
- c) that underlie all being and solve all questions of existence.

Through the tool of Science, we are able to understand God in its system and structure. Science evolves in us a divinely structured consciousness, until the structure of our consciousness reflects and is one with the structure of Being.

A NOTE ON COLOR CODING: Many students find it helpful to color-code the tones of the synonyms in their notes. There is no significance to the colors we have selected for each synonym above (the spectrum in a rainbow). Feel free to use this color scheme, or any other color scheme you wish, if you feel it will aid you in your study. The selection of color for category II and III (the 4-fold operation and 4 levels) do have significance, however, as they reflect the tones of the synonyms from which they are derived (Principle, Life, Truth, Love).

References:

Books by Max Kappeler:

The Four Levels of Spiritual Consciousness, pp.1–13.
Why Study Christian Science as a Science? (booklet)

Books by John W. Doorly:

Talks at the Oxford Summer School, 1949, Vol. II, pp. 268–273
 (the story of the one infinite system).

Recordings by Max Kappeler:

A-1: *An Introduction to the Science of Christian Science*, hours #15–16.
 A-4: *The Structure-principle of Being: Our need for a divine system of reference*, hours #4–22.
 D-4: *Divine Cybernetics and the Self-operating “Dimensional Laws” of the One Being, God*, hours #1–4.
 M-3: *The Divine System of Reference* (from D-4, hours #1–4).

EIGHT STAGES of the Development of Consciousness

1. atomistic thinking
2. linear thinking
3. functional thinking
4. operational thinking
5. structural consciousness
6. dimensional consciousness
7. divinely cybernetic consciousness
8. comprehensive consciousness

References:

Recordings by Max Kappeler

G-2: *The Science of Being—as I See it Today*, 8 hours.

B-2: *From Atomistic Thinking to Cybernetic Comprehensive Consciousness*, 27 hours.

STRUCTURE

Definition:

- Structure involves the interrelationships of parts as dominated by the general character of the whole (Webster).
- Structures appear whenever elements combine into a meaningful whole, whose arrangements follow definite laws (Wieser).

ATTITUDE

structural

- keeps the whole in view
- considers structure, relationships within and governed by the whole
- always has a new perspective
- center: the whole
- the whole has its own solution

atomistic

- narrow minded
- engulfed in details, pedantic
- routine, repetitive
- center: personal “I”
- meeting our own human and material desires

References:

Recordings by Max Kappeler:

C-1C: *CH. IX, Creation: The Structure of the Christian Science Textbook—Our Way of Life*, hours #1–2.

C-6: *Exercises in Culturing Consciousness According to the Matrix of Science and Health*, hours #1, 20.

D-4: *Divine Cybernetics and the Self-operating “Dimensional Laws” of the One Being, God*, hour #1.

G-2: *The Science of Being—As I See it Today*, hour #4.

M-12: *The Structural Method of Science* (from C-4, hours #1–2).

Books by Max Kappeler:

The Bible in the Light of Christian Science, Vol. I: Genesis, pp. 3–11.

The Science of the Oneness of Being in the Christian Science Textbook, pp. 52–53.

Category I

THE 7 SYNONYMOUS TERMS FOR GOD

Mind, Spirit, Soul, Principle, Life, Truth, Love

The Nature of Being

“*Question.*—What is God?

“*Answer.*—God is incorporeal, divine, supreme, infinite Mind, Spirit, Soul, Principle, Life, Truth, Love.

“*Question.*—Are these terms synonymous?

“*Answer.*—They are. They refer to one absolute God. They are also intended to express the nature, essence, and wholeness of Deity” (S&H 465: 8–14).

In our study of Science, it is important to begin with the divinely inspired definition of God as *Mind, Spirit, Soul, Principle, Life, Truth, Love*. To understand the importance and place value of these synonyms each synonym must be clearly differentiated from the others. This means that each one of the 7 synonyms for God must be defined through its individual characteristic nature—through its characteristic *ideas*. Therefore, each synonym for God can be defined through the ideas that characterize it *specifically* and *differentiate* it from the other synonyms.

Once we undertake a study of the individual nature of each synonym, we discover that the synonyms for God occur in specific contexts that are not freely interchangeable. Unfortunately, the belief still persists that because each of the synonyms stands for God, they must be freely interchangeable. But if this were so, we could ask: Why have seven terms, if one would do? Why complicate things, if it can all be so simple? The short answer is: Most students of Christian Science are not familiar with the meaning of the term “synonym,” or with the synonymy-principle that underlies the language of the Christian Science textbook.¹ In order to understand Christian Science in its *Science*, one must undertake a thorough examination of the 7 synonyms for God. The diagrams and tables in this section, Category I, will show the importance of the 7 synonymous terms for God in understanding Science, the Bible, and the nature of Being itself.

¹ It was on this fundamental question of the spiritually scientific meaning of the 7 synonymous terms for God that John Doorly was excommunicated from the Christian Science Church organization in 1946. For more on this topic, see John W. Doorly, *A Statement* and Max Kappeler, *Christian Government—Its Scientific Evolution*.

Recommended references for in-depth synonym study:

Books by Max Kappeler

The Seven Synonyms for God: An analysis of the concept of God in the Christian Science textbook, Chapters 1–7.

Complete Compendium for the Study of Christian Science

Recordings by Joel Jessen

J-1, *The 7 Synonymous Terms for God (S&H 465:10)* (24 hours)

Recordings by Max Kappeler

A-5, *A Seminar on the 7 Synonymous Terms for God* (23 hours)

A-6I, *Syllabus I* (33 hours)

A-6II, *Syllabus II* (28 hours)

A-6III, *Syllabus III* (27 hours)

THE PRISM AND LENS OF SCIENCE

An Explanation of Mary Baker Eddy's Statements (Mis. 194:13–18)

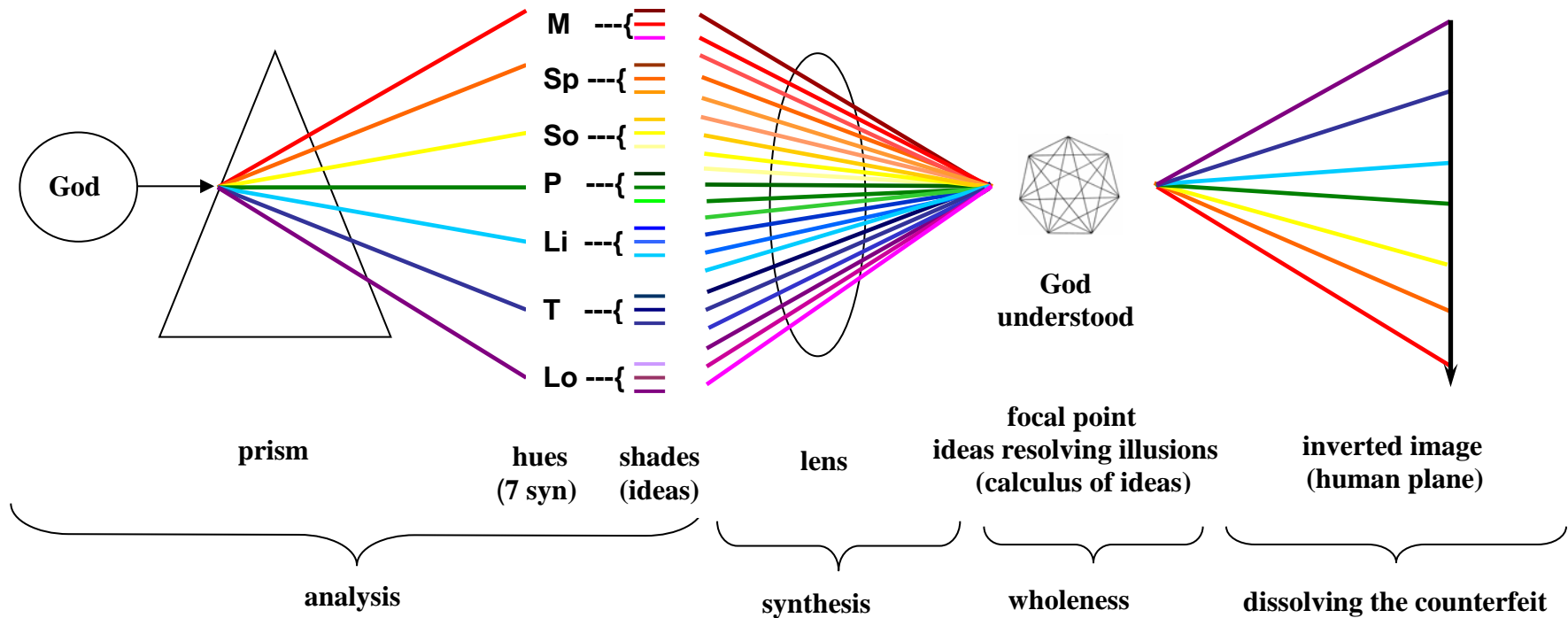

“Science is the prism of Truth, which divides its rays and brings out the hues of deity.”
(Ret. 35:13–14)

“The lens of Science magnifies the divine power to human sight; and we then see the allness of Spirit, therefore the nothingness of matter.”
(’01 12:22–24)

“The rays of infinite Truth, when gathered into the focus of ideas, bring light instantaneously...”
(S&H 504:23-24)

“Delusion, sin, disease, and death arise from the false testimony of material sense, which, from a supposed standpoint outside the focal distance of infinite Spirit, presents an inverted image of Mind and substance with everything turned upside down.”
(S&H 301:24–29)

References for “The Prism and Lens of Science”:

Books by Max Kappeler:

Introduction to the Science of Christian Science.

The Bible in the Light of Christian Science, Vol. I: Genesis, p. 93.

Recordings by Max Kappeler:

A-1: *An Introduction to the Science of Christian Science*, hour #3A.

A-4: *The Structure-principle of Being: Our need for a divine system of reference*, hours #4–6.

B-2: *From Atomistic Thinking to Cybernetic Comprehensive Consciousness*, hours #4–5.

D-4: *Divine Cybernetics and the Self-operating “Dimensional Laws” of the One Being, God*, hour #2.

G-2: *The Science of Being—As I See It Today*, hour #3.

RULES FOR STUDYING THE 7 SYNONYMOUS TERMS FOR GOD

1. The answer to the question: “How is the synonym characterized in this sentence?” must always name a characteristic of the synonym. It must convey something about the nature of the synonym itself and *not*, for example, man’s attitude towards a synonym.

For example, S&H 143:26: “Mind is the grand creator...” Here Mind is characterized as the creator.

Be sure to make a list of your findings.

2. As much as possible, try to answer with the letter of the text. Do not get sidetracked on developing long metaphysical arguments or expositions that are not in the simplicity of the reference itself.
3. Do not give your humanly subjective interpretation—“What the text says to me,” or “how the text inspires me.” The issue is: “What is the text telling us about the synonym?”—not our personal views.
4. Not every sentence with a synonym in it defines the synonym’s meaning.

For example, S&H 256:18: “...What is infinite Mind or divine Love?” This reference indicates no specific characteristic of either synonym.

5. Grammatically, a double negative statement can be put into the positive.

For example, S&H 1:10: “Thoughts unspoken are not unknown to the divine Mind.” In other words: Mind knows (all).

6. When you first begin this work, list only the very clear, conclusive findings; do not list those findings which are questionable.
7. Be careful in listing natural or biblical symbols such as “light,” “sword,” “warfare,” etc. Fundamentally, we should only list abstract terms which most clearly state the nature of the synonym.
8. Make a special list for the root counterfeits of every synonym.
9. Also, for now, omit combinations of two or more synonyms.

For example: Principle, Love; or Life, Truth, Love, etc.

10. Caution: Synonyms are often used in combination with ideas characterizing other synonyms to offset a counterfeit belief. In such cases, the ideas used are not intrinsically characteristic of the synonym with which they appear. For a discussion of this special use of synonyms, see Max Kappeler, *Complete Compendium for the Study of Christian Science*, Appendix 3 “The Study of Synonyms,” p. 258.
11. In blendings, the theme stated in a sentence determines which synonym must be used. We must ask: What is the theme presented in the text to be dealt with through the use of the synonym?
12. Because the synonyms all refer to God, there are ideas which are characteristic of all synonyms. Having a common referent—God—the synonyms have certain common characteristics among them. These shared characteristics should not be listed as uniquely characterizing any one synonym.
- For example: “divine” and “infinite” apply to all synonyms.
13. Continue your research over time. When this study is first undertaken, the findings will be only an approximation. Each succeeding research effort will weed out inaccuracies, clarifying and refining our understanding of the meaning of each synonym as it is characterized in the Textbook.

References:**Books by Max Kappeler:**

- The Seven Synonyms for God*, Chapter 1, especially “An important rule of interpretation” and “Guidelines for the study.”
Complete Compendium for the Study of Christian Science,
 Appendix 3, p. 258.
From the Physical, through the Mental, to the Spiritual, Chapter 5:
 The 7 Synonymous Terms for God, p. 49

Recordings by Max Kappeler:

- A-5: *A Seminar on the 7 Synonymous Terms for God*, hours #3–5A.
 A-6Ia: *The Rules for Studying the 7 Synonymous Terms for God in Science and Health* (2 hours).
 A-6I: *Syllabus I* (31 hours).
 B-2: *From Atomistic Thinking to Cybernetic Comprehensive Consciousness*, hours #5–6.

The ideas of MIND

creator

creates, makes
produces
creative power
made all
creative impulse

producer

parent Mind

forms

shapes, models
fashions

cause

causative
First Cause
origin, author
source

first

beginning

basis

power

force

action

movement

emanation

proceeds from
issues
flows forth
springs from

influence

ideas

image

model

thoughts

light

presents
brings to light
illuminates
comprehension
illumination
vision
discovery

manifests

will to express itself

all-knowing

knows, comprehends
apprehends
perceives
all-hearing
foretells, foresees
information
transmits

intelligence

attractive force
adhesion, cohesion
Mind-force
associations of ideas
wisdom

Mind of Christ

Mind-reading

faculties

spiritual seeing,
hearing, feeling

guidance

leads, steers
directs

unerring

corrects

will

volition
willingness

mandate

law

controls

regulates

governs

heals

healing power
Mind-healing
Mind-science

medicine

saves

helps

maintains

sustains

limitless

fetterless
unsearchable
unfathomable

All-in-all

All, all

the one Mind

NEGATIVE

mortal mind

ignorance, illusions
matter
erring, carnal,
negative mind
a mind of one's own

animal magnetism

mesmerism, occultism
hypnotism, astrology
clairvoyance

ignorance

halfway knowledge
sensuous reason
petty intellect

drugs, brain, nerves

The ideas of SPIRIT

Spirit separates ideas from illusions

dividing line
no point of contact
never mingles
excludes matter

understanding

faculty of discernment

warfare between the flesh and Spirit

the strength of Spirit

uncompromising firmness
firm standpoint

leaven–alchemy

understanding transforms
chemicalization

birth

brings forth
scientific obstetrics
newness of life

development

unfoldment
evolution

offspring

bears fruit

order

ordered sequence
law of order: like produces like

purity

baptism

burial

worship

focus
centered

reflection

focal point, rhythm
diversifying
classifying
individualizing
infinite calculus

likeness

good

substance

reality

the real
actualities
positive
tangible

nature

qualities

supply

spiritual realities

the only

only one
no opposite or other

NEGATIVE

dualism

matter

subjective state of mortal mind

flesh

belief of life or substance in matter

spiritualism

The ideas of SOUL

from sense to Soul

wandering
spiritual idea appearing

identity

name
spiritual identities
characteristics
coincidence
oneness in essence
selfhood
identity of interests

names

defines
definite
identification

man, the representative

the expression of God

spiritual understanding

outside body

never “in” anything

the greater controls

the lesser

master

resurrection

spiritual sense

Soul-sense
constant, steadfast

reverses

exchanges,
transforms

unchangeable

changeless
no loss
no forgetfulness
never injured, intact
undisturbed,
unimpaired
steadfastness
regularity
constancy
immortality

carries the seed

within itself

reproduces itself
kind, gender

capacity

withinness

sinless

immortality

freedom

joy, happiness, satisfaction

balance
rejoices
beauty, grace

self-abnegation

rule

NEGATIVE

the material senses

body

sin

sensation

ecstasy, emotion
passion
propensities
sufferings, sorrows
pleasures
feelings

counterfeits per se

The ideas of PRINCIPLE

the creative Principle: Mind, Spirit, Soul

creative nature

the triune Principle: Life, Truth, Love

essence

trinity in unity

Father, Son, Mother

triune Person

the sevenfold Principle

wholeness

central point

Principle of all

Supreme Being

all ideas have the same Principle

Principle and its idea

the idea must be seen in its Principle

Principle and its idea is one

relationship

the unity of God

atonement / at-one-ment

inseparable

divine coincidence

universe

harmony

system

government

theocracy

absolute

immutable, fixed

apodictical

imperative

never pardons

never repents

correction

obedience to Principle

demonstrates itself

spiritual power

operates

proves itself

ever-operative

working out all good

always at work

interprets itself

expounds

explains, states

God is the Principle of all sciences

solves all problems

NEGATIVE

personality, personal sense

anthropomorphism

material organization

theories

opinions

lack of Principle

without Principle

hypocrisy

dishonesty

disloyalty

The ideas of LIFE

Principle–Life

Life-principle

Father

co-existence

self-sustaining

sustainer

self-creating

self-existent

God is the Life of man

only one Life

here and now

ever-present

exaltation

rise in consciousness

giving up the mortal concept of existence

to love God means Life

multiplication

stream of ever-new ideas

abundance, supply

grace, inspiration

newness and spontaneity of life

resuscitates

regenerates

the way of Life

method

following the way

individuality

existence

ever-present

present condition of perfection

now, now-ness

being

eternal

now-ness

is-ness

everlasting newness

without beginning, without end

spontaneous

permanency

continuity

indestructible

cannot be annihilated or erased

deathless

immortality

NEGATIVE

material life

Life is never in nor of matter

organic life

organizations, embryonic, mortal life

food, blood, time

death

The ideas of TRUTH

Truth

actuality of God
truthfulness

Life—Truth

Truth must be sought

motives of truth
sincerity and
righteousness

the key to harmony

state of consciousness

claim Truth

claims of Truth
accept, affirm Truth
adherent of Truth
standing for Truth
testify, be steadfast
denying erroneous
concepts

trust Truth

unshakable
dependable, unswerving
rock, cornerstone

standard

ideal standards
standard of ideas

ideal

son

Messiah or Christ
child of God
heir appropriates
inheritance
possesses, claims, affirms
self-asserting
self-claiming
self-affirming

Christ

consciousness

man

ideal man
compound idea
generic man
male and female
qualities
individual consciousness
of perfection

health

form

faultless

the voice of Truth

revelation

reveals itself
awakens spirituality

the light of Truth

radiance, sunshine
of Truth
true light
unveils and uncovers

the utilization of Truth

the seed of Truth

the leaven of Truth

chemicalization

the sword of Truth

two-edged sword

power to prevail

energy, potency
enforces itself
healing power

destroys error

dispels, deprives
annihilates, removes
obliterates, consumes
overcomes, conquers
vanquishes, triumphs

remedy

alterative
universal panacea

dominion

deliverer

NEGATIVE

error

contradiction
unlikeness
opposite of Truth
simulation of Truth
falsity
absence of Truth
nothingness

lie

falsehood
denial of Truth

sickness

The ideas of LOVE

God is Love

spiritual climax
sum total of Deity

Truth-Love

love of truth

mother

motherhood, mothers

imparts all good

bestows, gives,
imparts all
inexhaustible gifts
makes man a partaker

meets human needs

inexhaustible

to the fullest extent
abundance, profusion
complete sufficiency

universal

universality
impartial
omnipresent
world-citizen

perfection

completeness
highest excellence

fulfillment

inseparable union

oneness, wedded
inner conviction
self-sufficiency
self-containment
united, held in Love
perfectibility
never deserted
accept, receive
attraction

brings full compensation

fully counterbalances

womanhood

divinely feminine
ideal woman:
Life and Love

ministering Love

all-ministering

loveliness

loving attitude
love of our true self
clear intellect plus
a loving heart
amplitude of pure
affection
sympathy, devotion
goodness, beauty
comeliness, grace

chastens

forces to accept

blesses all

forgives

knows no temptation

does not tempt

knows no error

universal solvent
error is excluded
no contest

redemption

deliverance
miracle of grace

protection

holiness, glory

glorification

rest

peace

plan

design, purpose
collective plan

Christianity

NEGATIVE

fear

hate

antipathy

enmity

envy, jealousy
victimization
favoritism
vengeance, cruelty
malice, treachery
curse, damnation
partiality

Recommended references for studying “The Ideas of Mind, Spirit, Soul, Principle, Life, Truth, Love”

“The ideas of Mind”:

Books by Max Kappeler:

A Study Aid for the Science of Christian Science, p. 6
Complete Compendium for the Study of Christian Science, #4: Mind
The Science of the Oneness of Being in the Christian Science Textbook, pp. 41–45, overview
The Seven Synonymous Terms for God, Chapter 1. See Appendix.

Recordings by Max Kappeler:

A-4: *The Structure-principle of Being: Our need for a divine system of reference*, 1974, Wilmington, DE, hours 10–12A
A-6I: *Syllabus I*, Class, 1977, hours 1–8A

Books by John Doorly:

The Pure Science of Christian Science, pp. 42–47, 98–126, 157–189

“The ideas of Spirit”:

Books by Max Kappeler:

A Study Aid for the Science of Christian Science, p. 7
Complete Compendium for the Study of Christian Science, #5: Spirit
The Seven Synonymous Terms for God, Chapter 1

Recordings by Max Kappeler:

A-6I: *Syllabus I*, 1977, hours 8B–14

“The ideas of Soul”:

Books by Max Kappeler:

A Study Aid for the Science of Christian Science, p. 8
Complete Compendium for the Study of Christian Science, #6: Soul
The Seven Synonymous Terms for God, Chapter 1.

Recordings by Max Kappeler:

A-6I: *Syllabus I*, 1977, hours 14–19.

“The ideas of Principle”:

Books by Max Kappeler:

A Study Aid for the Science of Christian Science, p. 9
Complete Compendium for the Study of Christian Science, #7: Principle
The Seven Synonymous Terms for God, Chapter 1

Recordings by Max Kappeler:

A-6I: *Syllabus I*, 1977, hours 20–23

“The ideas of Life”:

Books by Max Kappeler:

A Study Aid for the Science of Christian Science, p. 10
Complete Compendium for the Study of Christian Science, #8: Life
The Seven Synonymous Terms for God, Chapter 1

Recordings by Max Kappeler:

A-6I: *Syllabus I*, 1977, hours 23B–25A

“The ideas of Truth”:

Books by Max Kappeler:

A Study Aid for the Science of Christian Science, p. 11
Complete Compendium for the Study of Christian Science, #9: Truth
The Seven Synonymous Terms for God, Chapter 1

Recordings by Max Kappeler:

A-6I: *Syllabus I*, 1977, hours 25B–28A

“The ideas of Love”:

Books by Max Kappeler:

A Study Aid for the Science of Christian Science, p. 12
Complete Compendium for the Study of Christian Science, #10: Love
The Seven Synonymous Terms for God, Chapter 1

Recordings by Max Kappeler:

A-6I: *Syllabus I*, 1977, hours 28–29

Understanding and Demonstration

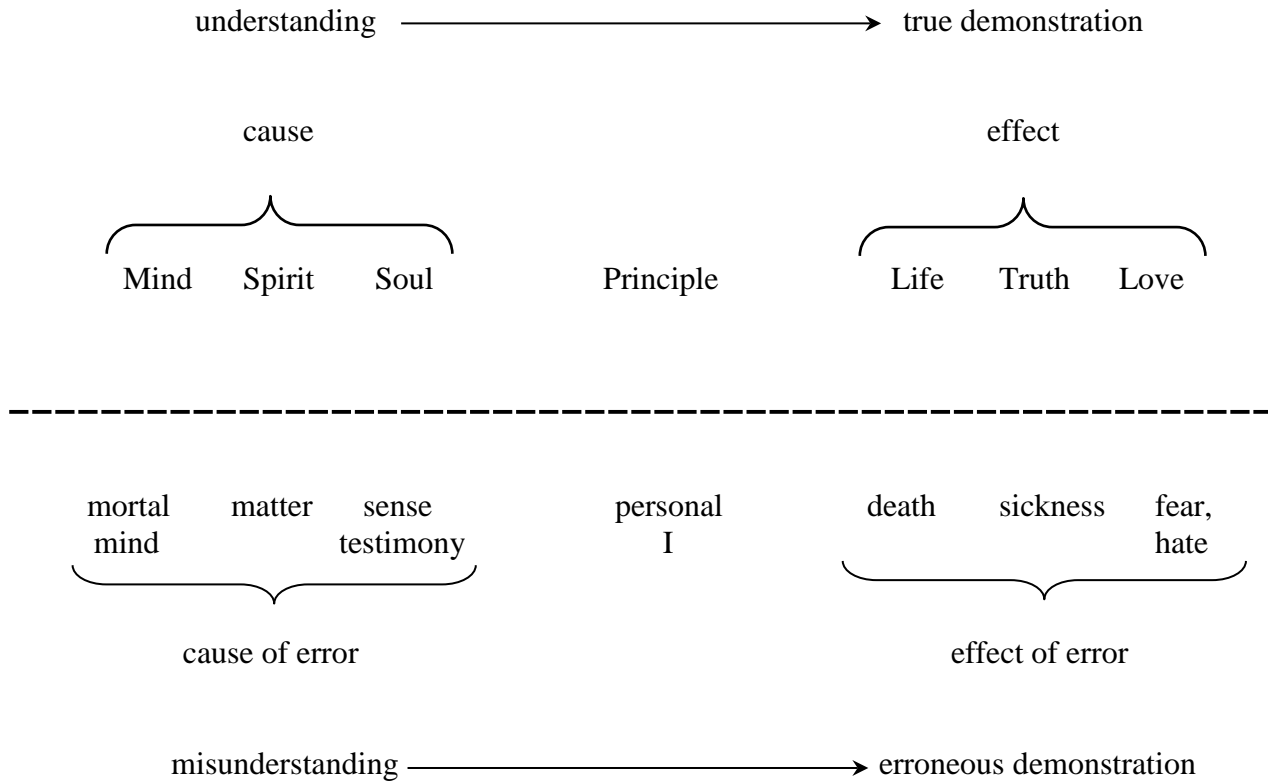

References:

Books by Max Kappeler:

The Four Levels of Spiritual Consciousness, pp. 174–181.

Recordings by Max Kappeler:

D-2: *Divine Cybernetics: The proto-science, the integral Science*, hour #10B.

D-4: *Divine Cybernetics and the Self-operating “Dimensional Laws” of the One Being, God*, hour #8.

The Stages of Culturing Spiritual Consciousness

1. **Concept-building:**

Getting the concepts clear:

- a) in what they mean through text-analysis.
- b) as defined through their relationships.

What we do: Think through the concepts to establish the perfect concept, or “idea.”

2. **Tonality-building:**

Seeing all the ideas of a synonym tightly interwoven so as to form one overall tone of a synonym, including all ideas.

What we do: Ponder the ideas together to establish the tone of the synonym itself, embracing all ideas.

3. **Consciousness-building:**

“Thinking about” the synonym melts into a pure consciousness of the synonyms — “thinking from” the synonyms in divinely differentiated consciousness; the divinely objective becomes humanly subjective.

What we do: Mother the synonyms in consciousness.

4. **Being-building:**

Consciousness determines being; the consciousness of the 7 synonyms for God becomes our only being.

References:

Books by Max Kappeler:

The Seven Synonyms for God, Chapter 5.

Recordings by Max Kappeler:

A-5: *A Seminar on the 7 Synonymous Terms for God*, hours #1–3A, #5–10A, #18B–19A.

A-6II: *Syllabus II*, hours #3–4A.

Books by John Doorly:

Christian Science Practice, pp. 36–37.

Talks at the Oxford Summer School, 1948, Vol. I, pp. 46–48, 55, 178–179.

Talks at the Oxford Summer School, 1949, Vol. I, pp. 8, 60–61.

Talks at the Oxford Summer School, 1949, Vol. II, pp. 255–257.

Talks on the Science of the Bible, #66 (blue-book), p. 29.

Talks on the Science of the Bible, #68 (blue-book), pp. 18–19 (the meaning and use of the term “tone”).

Talks on the Science of the Bible, Vol. I (red-book), p. 62–63, 126–127, 291–292.

Talks on the Science of the Bible, Vol. II (red-book), pp. 20–21, 79–80, 83–84, 97, 125–126, 165, 313–314.

Talks on the Science of the Bible, Vol. III (red-book), pp. 193–194, 202–203, 261–262, 323–324, 353–355.

Talks on the Science of the Bible, Vol. IV (red-book), pp. 43–44, 107–108, 142–143.

Talks on the Science of the Bible, Vol. V (red-book), pp. 102–103.

Mortal Consciousness

1. Mortal mind is the basis of mortal consciousness.
2. Mortal mind brings forth all disharmony.
3. Different forms of mortal consciousness:
 - individual beliefs
 - collective beliefs
 - universal beliefs
 - conscious and unconscious beliefs
 - archetypal beliefs
4. Mortal consciousness is not personal.
5. In mortal consciousness, the greater controls the lesser:
 - majority beliefs govern minority beliefs
 - the stronger beliefs govern the weaker
 - faith in medicine and in the doctor governs
 - belief in truth is the first step
 - in the long run, a belief in truth is not enough
 - scientific understanding governs all beliefs
6. Mortal consciousness is the counterfeit of divine Mind.
7. Mortal consciousness is nothing.

References:

Books by Max Kappeler:

Introduction to the Science of Christian Science, pp.83–96.

Recordings by Max Kappeler:

A-1: *An Introduction to the Science of Christian Science*, hours #7–9
(also listed as M-10).

A-4: *The Structure-principle of Being: Our need for a divine system of reference*, hours #2B–3.

The Seven Days of Creation

An overall view

How the nature of God,
revealed through the seven days of creation,
translates itself to our seeking attitude.

Synonym	Symbol	The nature of God	Our approach to God
Mind	light	Intelligence, creative power	Open thought, willingness to learn without human preconceptions
Spirit	firmament	The onliness of spiritual reality, separating the real from the unreal and bringing understanding	Turning toward Spirit and away from materiality; valuing the spiritual above all else
Soul	dry land, seed within itself	The definiteness of spiritual identity, which names and defines all	Being humble and willing to let Soul name and define all things rightly
Principle	sun, moon, stars, to give light	The divine system of Principle governing the universe; scientific metaphysics demonstrating spiritual power.	Having a scientific and divinely principled attitude; being honest and consistently obedient to the spiritual
Life	teeming of fish and fowl	Fullness, abundance, multiplication, exaltation	Willingness to live by the Life-source by laying down false concepts of life
Truth	every living creature: animals and man	Spiritual consciousness, spiritual manhood, dominion	Letting spiritual consciousness have dominion in our life; working from the whole through its Science and structure
Love	creation finished, rest	Fulfillment, peace, the perfection of completely integrated being	Accepting and acknowledging the present perfection of being; resting in God's plan of salvation

References for “The Seven Days of Creation: An overall view”

Books by Max Kappeler:

The Bible in the Light of Christian Science, Vol. I: Genesis, pp. 11–13, 30–36.

Complete Compendium for the Study of Christian Science, pp. 41, 508.

The Four Levels of Spiritual Consciousness: Science itself, divine Science, absolute Christian Science, Christian Science, pp. 29–59.

The Seven Synonyms for God, Chapter 2, p. 65.

The Structure of the Christian Science Textbook, Vol. I: Revelation of the Structure, pp. 163–167.

Recordings by Max Kappeler:

A-5: *A Seminar on the 7 Synonymous Terms for God*, hour #15.

A-6III: *Syllabus III*, hours #1–6.

C-1G: *CH. XV, Genesis, The Structure of the Christian Science Textbook—Our Way of Life*, hour #5A.

D-4: *Divine Cybernetics and the Self-operating “Dimensional Laws” of the One Being, God*, hour #7.

Books by John Doorly:

Christian Science Practice, pp. 26–29, 59–61.

God and Science, pp. 36–48.

The Pure Science of Christian Science, p. 41.

Talks at the Oxford Summer School, 1948, Vol. I, pp. 16–18.

Talks on the Science of the Bible, Vol. I (red-book), pp. 41–183, 307–318.

**The First Record of Creation:
the seven days with their subtones**
(Genesis 1:3–2:3)

<i>day</i>	<i>Bible: Genesis</i>	<i>metaphysical meaning</i>	<i>Science</i>
1st	<p>1. light (Gen. 1:3–5)</p> <p>1. let there be light 2. light was good, divided from the darkness 3. light was called day; darkness was called night</p>	<p>1. creative ability, intelligence</p> <p>1. creates all in ideas 2. ideas are only good 3. record of ideas</p>	<p>1. Mind</p> <p>1. as Mind 2. as Spirit 3. as Soul</p>
2nd	<p>2. firmament (Gen. 1:6–8)</p> <p>1. let there be a firm- ament to divide 2. firmament divided the waters 3. the firmament is called heaven</p>	<p>2. understanding</p> <p>1. separates ideas from human conceptions 2. reality brought to light 3. secures ordered progress</p>	<p>2. Spirit</p> <p>1. as Mind 2. as Spirit 3. as Soul</p>
3rd	<p>3. dry land, seed within itself (Gen. 1:9–13)</p> <p>1. let the water be gathered together; let the dry land appear 2. division of earth and sea is good 3. let the earth bring forth grass, herb, fruit tree, seed within itself 4. brought forth after its kind 5. third day: resurrection</p>	<p>3. identity</p> <p>1. ideas gather identity 2. identities have spiritual qualities 3. identities are self- reproducing 4. identities classified 5. identities are immortal</p>	<p>3. Soul</p> <p>1. as Mind 2. as Spirit 3. as Soul 4. as Principle 5. as Life</p>

The First Record of Creation: the seven days with their subtone (Genesis 1:3–2:3) (cont.)

<i>day</i>	<i>Bible: Genesis</i>	<i>metaphysical meaning</i>	<i>Science</i>
4th	4. lights: sun, moon, stars (Gen. 1:14–19) <ol style="list-style-type: none"> 1. let there be lights for signs, seasons, days, years 2. give light upon the earth 3. God made two great lights to rule, and the stars also 4. ruling over the day and the night 5. marking periods of progress 	4. creative ability, intelligence <ol style="list-style-type: none"> 1. basis: a system of ideas 2. reflects itself in demonstration 3. the greater ruling the lesser: harmony 4. interprets itself divinely 5. brings progressive interpretation 	4. Principle <ol style="list-style-type: none"> 1. as Mind 2. as Spirit 3. as Soul 4. as Principle 5. as Life
5th	5. fish and fowl (Gen. 1:20–23) <ol style="list-style-type: none"> 1. let the waters bring forth abundantly moving creature that has life, and fowl that fly above the earth 2. waters brought forth abundantly every living creature and every winged fowl after their kind 3. God blessed them: be fruitful and multiply 4. exalted beings 	5. fullness <ol style="list-style-type: none"> 1. Life is: ideational 2. spiritual 3. cognizant to spiritual sense 4. scientific 	5. Life <ol style="list-style-type: none"> 1. as Mind 2. as Spirit 3. as Soul 4. as Principle

The First Record of Creation: the seven days with their subtones (Genesis 1:3–2:3) (cont.)

<i>day</i>	<i>Bible: Genesis</i>	<i>metaphysical meaning</i>	<i>Science</i>
6th	6. animals and man (Gen. 1:24–31)	6. true manhood	6. Truth
	1. let the earth bring forth living creature, cattle, creeping thing, beast of the earth	1. consists of ideas	1. as Mind
	2. it was good	2. they are spiritual	2. as Spirit
	3. let us make man in our image after our likeness	3. individual identity	3. as Soul
	4. male and female	4. generic man as God’s ideal	4. as Principle
	5. be fruitful and multiply and replenish the earth	5. son of God has dominion	5. as Life
	6. man is given every herb, and fruit tree; beast is given green herb	6. compound idea man	6. as Truth
	7. everything was good	7. perfect womanhood	7. as Love
7th	7. creation finished (Gen. 2:1–3)	7. fulfillment	7. Love
	6. heavens, earth, and all the host of them finished	6. all-inclusive	6. as Truth
	7. God ended His work and rested from all His work	7. holiness	7. as Love

References:

Books by Max Kappeler:

- The Bible in the Light of Christian Science*, Vol. I: ‘Genesis,’ pp. 41–183, 307–318.
- Epitomes for the Spiritually Structured Interpretation of the Christian Science Textbook*, ‘Genesis,’ pp. 3–4.
- The Four Levels of Spiritual Consciousness: Science itself, divine Science, absolute Christian Science, Christian Science*, pp. 29–59 (especially the sixth and seventh days).

Recordings by Max Kappeler:

- A-6III: *Syllabus III*, Class, 1978, hours 1–6.
- C-1G: *CH. XV, Genesis, The Structure of the Christian Science Textbook—Our Way of Life*, Series of Talks: 1981, hour 5A.

The Seven Days of Creation (Genesis 1:3–2:2)
The WORD OF GOD in the four aspects: Word, Christ, Christianity, Science

	WORD AS WORD	WORD AS CHRIST	WORD AS CHRISTIANITY	WORD AS SCIENCE			
	1 st Day	2 nd Day	3 rd Day	4 th Day	5 th Day	6 th Day	7 th Day
MIND	MIND/MIND 1:3	SPIRIT/MIND 1:6	SOUL/MIND 1:9	PRINCIPLE/MIND 1:14	LIFE/MIND 1:20	TRUTH/MIND 1:24	
SPIRIT	MIND/SPIRIT 1:4	SPIRIT/SPIRIT 1:7	SOUL/SPIRIT 1:10	PRINCIPLE/SPIRIT 1:15	LIFE/SPIRIT 1:21	TRUTH/SPIRIT 1:25	
SOUL	MIND/SOUL 1:5	SOUL/SOUL 1:8	SOUL/SOUL 1:11	PRINCIPLE/SOUL 1:16	LIFE/SOUL 1:22	TRUTH/SOUL 1:26	
PRINCIPLE			SOUL/PRINCIPLE 1:12	PRINCIPLE/PRINCIPLE 1:17–18	LIFE/PRINCIPLE 1:23	TRUTH/PRINCIPLE 1:27	
LIFE			SOUL/LIFE 1:13	PRINCIPLE/LIFE 1:19		TRUTH/LIFE 1:28	
TRUTH						TRUTH/TRUTH 1:29-30	LOVE/TRUTH 2:1
LOVE						TRUTH/LOVE 1:31	LOVE/LOVE 2:2

References for “The Seven Days of Creation (Genesis 1:3–2:2), The WORD OF GOD in the four aspects: Word, Christ, Christianity, Science”

Books by Max Kappeler:

The Bible in the Light of Christian Science, Vol. I: ‘Genesis,’ pp. 63, 250–253, 274–277, 279–280.

Recordings by Max Kappeler:

A-6III: *Syllabus III*, Class, 1978 – Wilmington, (DE), hour 15B.

C-1G: *CH. XV, Genesis, The Structure of the Christian Science Textbook—Our Way of Life*,
Series of Talks: 1981, hours 11–13.

E-2: *The Matrix of Immortality: Code of divine laws*, Class, 1974 – Wilmington, (DE), hours 10–11A.

Books by John W. Doorly:

Talks at the Oxford Summer School, 1948, Vol. I, pp. 24–25, 214–215.

The Days of Creation The Layout of Word in its four aspects

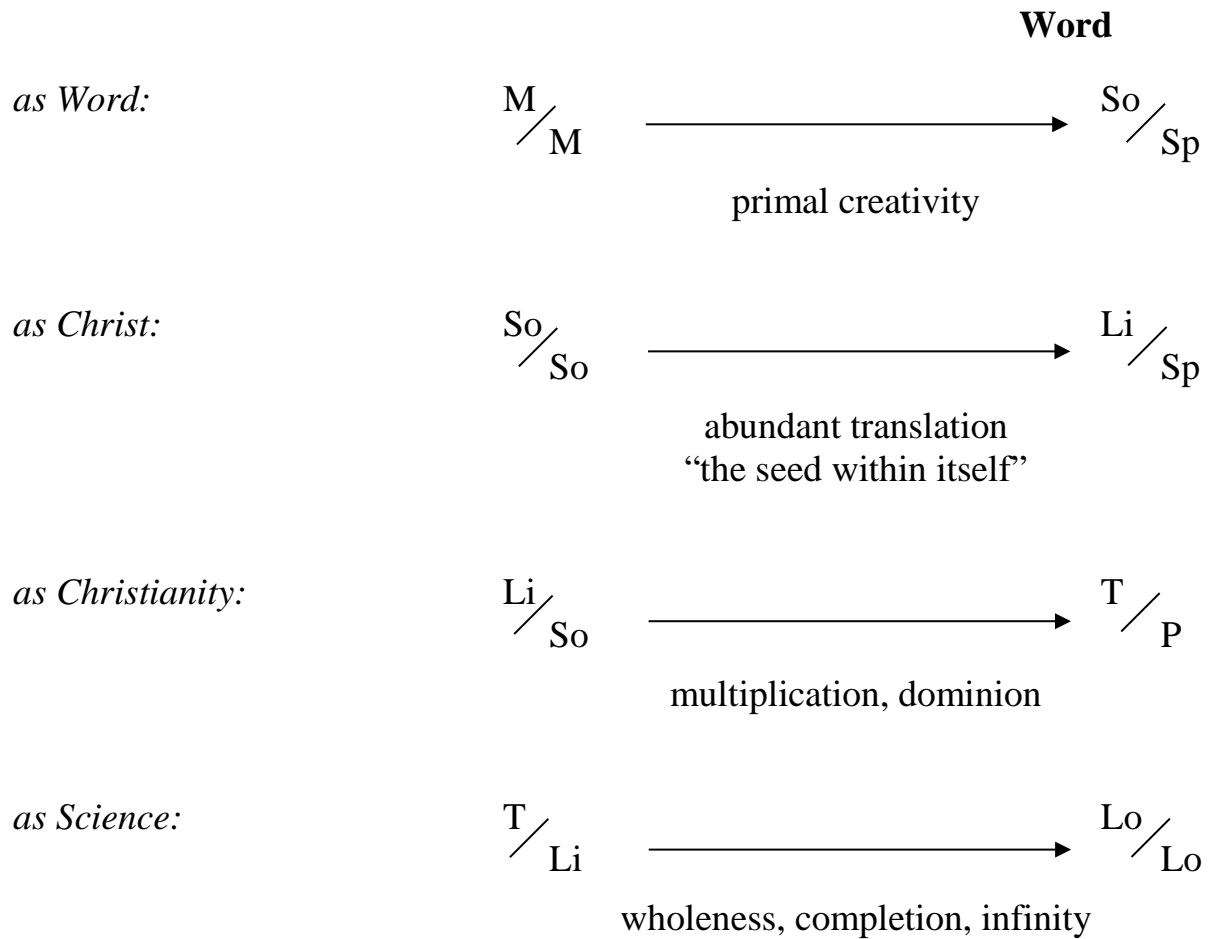

References:

Books by Max Kappeler:

Epitomes for the Spiritually Structured Interpretation of the Christian Science Textbook, ‘Genesis,’ p. 4.

Recordings by Max Kappeler:

C-1G: *CH. XV, Genesis, The Structure of the Christian Science Textbook—Our Way of Life, Series of Talks:* 1981, hours 11–12A
 E-2: *The Matrix of Immortality: Code of divine laws,* Class, 1974 – Wilmington, (DE), hour 11A.

The Second Record of Creation
An overall view:

<i>synonyms</i>	<i>symbol</i>	<i>counterfeit belief</i>
Mind	mist	ignorance
Spirit	Adam formed of dust and breath; the tree of knowledge of good and evil	duality: trying to mingle Spirit and matter, good and evil
Soul	Adam put into the garden of Eden (body, five senses) Adam named every living creature	corporeal senses: being in a body and defined by the physical senses; false identification
Principle	deep sleep: Eve made of Adam's rib	animal magnetism and mesmerism: division, atomism working from the false system of mortal beliefs
Life	serpent: Eve eats from the tree of knowledge of good and evil; nakedness and hiding	mortality: demoralization, downfall, lack, emptiness, the burden of mortal life
Truth	mortal manhood: Eve cursed to bring forth in sorrow; Adam cursed to till the ground and return to dust; Cain kills Abel	mortal consciousness: slavery, condemnation, self-destruction of error
Love	Cain went out from the presence of the Lord and dwelt in the land of Nod	error excluded: returns to oblivion

References:

Books by Max Kappeler:

The Bible in the Light of Christian Science, Vol. I: 'Genesis,' pp. 39–54.
The Structure of the Christian Science Textbook, Vol. I, pp. 167–170.

Recordings by Max Kappeler:

C-1G: *CH. XV, Genesis, The Structure of the Christian Science Textbook—Our Way of Life*, Series of Talks: 1981, hours 16–20.

Books by John W. Doorly:

Talks on the Science of the Bible, Vol. I "red-book," pp. 184–318.

God and Science—symbols and their importance, pp. 71–79.

**The Second Record of Creation:
main tones and subtones
(Genesis 2:6–5:24)**

<i>day</i>	<i>Bible: Genesis</i>	<i>metaphysical meaning</i>	<i>Science</i>
1st	1. mist (Gen. 2:6) 1. a mist went up from the earth 2. and watered 3. the whole face of the ground	1. ignorance 1. ignorance evolves a false creative sense 2. from a false creative sense arises the belief of material creation 3. this involves a false sense of God (idolatry)	1. Mind 1. as Mind 2. as Spirit 3. as Soul
2nd	2. dust; tree of knowledge (Gen. 2:7–14) 1. Adam formed from dust and breath of life 2. the tree of life and the tree of knowledge of good and evil 3. every tree pleasant to the sight	2. mingling of Spirit and matter 1. produces a mortal 2. material beliefs are dualistic 3. these involve sensations in matter	2. Spirit 1. as Mind 2. as Spirit 3. as Soul
3rd	3. garden of Eden (Gen. 2:15–20) 1. Adam put into the garden of Eden to dress it 2. eating from the tree of knowledge of good and evil brings death 3. Adam needs a help meet	3. the corporeal senses 1. the belief of Mind in matter constitutes the physical senses 2. knowledge from the physical senses constitutes evil; death 3. physical sense is unsatisfied within itself	3. Soul 1. as Mind 2. as Spirit 3. as Soul

The Second Record of Creation: main tones and subtones (Genesis 2:6–5:24) (cont.)

<i>day</i>	<i>Bible: Genesis</i>	<i>metaphysical meaning</i>	<i>Science</i>
3rd (cont.)	4. Adam gave names to every living creature 5. for Adam there was not found a help meet	4. this develops animal qualities 5. but they cannot bring forth a new creature	4. as Principle 5. as Life
4th	4. deep sleep (Gen. 2:21–3:3) 1. deep sleep: a rib taken out 2. woman made from the rib 3. man and woman are one flesh 4. the serpent misinterprets the Lord's commandments 5. eating from the tree of knowledge brings death	4. animal magnetism (a false system) 1. animal magnetism operates as isolated beliefs breaking up the system 2. it brings forth material fruits 3. and disidentifies man from God 4. animal magnetism misinterprets God to man 5. misinterpretation increases mortality	4. Principle 1. as Mind 2. as Spirit 3. as Soul 4. as Principle 5. as Life
5th	5. serpent (Gen. 3:4–8) 1. serpent: ye shall be as gods, knowing good and evil 2. Eve ate the fruits 3. eyes were opened; they knew that they were naked 4. aprons from fig leaves; they hid themselves	5. mortality 1. mortality rests on dualistic knowledge 2. materiality cannot sustain life 3. the corporeal senses multiply mortality 4. a system of beliefs is doomed to oblivion	5. Life 1. as Mind 2. as Spirit 3. as Soul 4. as Principle

The Second Record of Creation: main tones and subtones (Genesis 2:6–5:24) (cont.)

<i>day</i>	<i>Bible: Genesis</i>	<i>metaphysical meaning</i>	<i>Science</i>
6th	6. Cain slays Abel (Gen. 3:9–4:15)	6. mortal manhood	6. Truth
	1. Adam blames Eve and God	1. material consciousness blames God for an evil mind	1. as Mind
	2. the serpent beguiled me; enmity between the serpent and the woman; in sorrow shalt thou bring forth children	2. carnal consciousness is enmity against the spiritual idea	2. as Spirit
	3. Adam cursed to live in sorrow and to return to dust	3. corporeal consciousness with its sorrows returns to nothingness	3. as Soul
	4. Adam driven out from Eden so as not to become like a god; condemned to till the ground	4. personal consciousness excludes harmony	4. as Principle
	5. Eve bore Cain and Abel; the offspring of Cain and Abel	5. mortal consciousness creates mortal mankind	5. as Life
	6. Cain slew Abel; Cain cursed	6. erroneous consciousness disrupts brotherhood and brings condemnation	6. as Truth
	7. sevenfold vengeance for slaying Cain	7. imperfect consciousness receives penalty of self-destruction	7. as Love
7th	7. went out of the presence of the Lord (Gen. 4:16–5:24)	7. the realm of nothingness	7. Love
	6. Cain went out of the presence of the Lord	6. mortality falls into complete oblivion	6. as Truth
	7. Cain dwelt in the land of Nod	7. mortality is not	7. as Love

References:**Books by Max Kappeler:**

Epitomes for the Spiritually Structured Interpretation of the Christian Science Textbook, 'Genesis,' pp. 5–6.

Recordings by Max Kappeler:

C-1G: *CH. XV, Genesis, The Structure of the Christian Science Textbook—Our Way of Life*, Series of Talks: 1981, hours 16–20.

Books by John Doorly:

Talks on the Science of the Bible, Vol. I “red-book,” pp. 184–318.

Metaphysical comparison between 1st and 2nd Records of Creation

<i>true record of creation</i>	<i>false record of creation</i>
<p>1. Creative ability; intelligence:</p> <ol style="list-style-type: none"> 1. creates all in ideas 2. ideas are only good 3. record of ideas 	<p>Ignorance:</p> <ol style="list-style-type: none"> 1. false creative sense 2. myth of material creation 3. idolatry
<p>2. Understanding</p> <ol style="list-style-type: none"> 1. separates idea from human conceptions 2. reality brought to light 3. secures ordered progress 	<p>Mingling of Spirit and matter</p> <ol style="list-style-type: none"> 1. produces an evil creation 2. dualistic 3. involves sensation in matter
<p>3. Identity</p> <ol style="list-style-type: none"> 1. ideas gather identity 2. identities have spiritual qualities 3. identities are self-reproducing 4. identities classified 5. identities are immortal 	<p>Corporeal senses</p> <ol style="list-style-type: none"> 1. belief creates sensation of body 2. material knowledge is evil 3. are not self-reproducing 4. classify according to animal qualities 5. cannot bring forth a new creation
<p>4. System of ideas</p> <ol style="list-style-type: none"> 1. basis: a system of ideas 2. reflects itself in demonstration 3. the greater ruling the lesser: harmony 4. interprets divinely 5. brings progressive interpretation 	<p>Animal magnetism (false system)</p> <ol style="list-style-type: none"> 1. basis: isolated beliefs 2. demonstrates material fruits 3. disidentification with God disrupts harmony 4. misinterprets God to man 5. this increases mortality
<p>5. Fullness</p> <ol style="list-style-type: none"> 1. Life is ideational 2. spiritual 3. cognizant to spiritual sense 4. scientific 	<p>Mortality</p> <ol style="list-style-type: none"> 1. basis: dualistic knowledge 2. brings only mortal life 3. is testified by corporeal senses 4. unscientific; leads nowhere
<p>6. True manhood</p> <ol style="list-style-type: none"> 1. consists of ideas 2. they are spiritual realities 3. individual identity 4. generic man as God's ideal 5. son of God has dominion 6. compound idea man 7. perfect womanhood 	<p>Mortal manhood</p> <ol style="list-style-type: none"> 1. material mindedness 2. carnal consciousness (enmity against the spiritual) 3. corporeal consciousness (sorrows) 4. personal consciousness 5. mortal consciousness 6. erroneous consciousness (disruptive) 7. imperfect consciousness (self-destruction)
<p>7. Fulfillment</p> <ol style="list-style-type: none"> 6. all-inclusive 7. holiness 	<p>Realm of nothingness</p> <ol style="list-style-type: none"> 6. oblivion 7. "is not"

References for “Metaphysical comparison between 1st and 2nd Records of Creation”

Books by Max Kappeler:

The Bible in the Light of Christian Science, Vol. I: Genesis, p 54.

Introduction to the Science of Christian Science, pp.58–67.

Notes on Handling Evil, esp. p. 5.

Recordings by Max Kappeler:

A-4: *The Structure-principle of Being: Our need for a divine system of reference*, Class 1974
– Wilmington, (DE), hour 4B.

C-1G: *CH. XV, Genesis, The Structure of the Christian Science Textbook—Our Way of Life*,
Series of Talks: 1981, hours 16–17A.

Books by John Doorly:

God and Science—Symbols and their Importance, pp. 77–78.

Talks on the Science of the Bible, Vol. I “red-book,” pp. 227, 243–244, 247–250, 307–318.

The Thousand-year Periods
“One day is with the Lord as a thousand years”
(S&H 504:16–26; 537:19–24)

<i>synonyms</i>	<i>1000-year period</i>	<i>spiritual meaning</i>	<i>symbol/reality</i>
Mind	Adam to Enoch (c. 4000–3000 BC)	awakening from ignorance (the mist of Eden) to follow the light of the spiritual idea (Enoch walks with God)	myth
Spirit	Noah story with the flood to tower of Babel (c. 3000–2000 BC)	turning away from material beliefs to build an ‘ark’ of understanding, remaining with the purity and onliness of spiritual ideas	legends, sagas
Soul	Abraham, Isaac, Jacob, Joseph into Egypt, Moses leading people out of Egypt, entering the Promised Land, Joshua, Judges (c. 2000–1000 BC)	going the way from sense (Ur, Egypt) to Soul (Canaan, the Promised Land), exchanging a physical, corporeal identity for our spiritual selfhood	tribal history
Principle	the Kingdom period and the prophetic age (c. 1000 BC–1 AD)	rejecting personal or material government and finding true government through prophecy, through Principle’s system of ideas	revelation of the idea of God
Life	the life of Jesus, the apostles, Paul and the spreading of Christianity (c. 1–1000 AD)	laying down a mortal, material sense of life and accepting the newness and fullness of Life in and of Spirit as a gift of grace	unity of Jesus and idea (Christ Jesus)

The Thousand-year Periods, “One day is with the Lord as a thousand years,”(S&H 504:16–26; 537:19–24), continued

Truth	(c. 1000–2000 AD)	the rise of scientific consciousness, grounding our understanding of true being and manhood in scientific methods	unity of Science and idea (Christ Science)
Love	(c. 2000 AD)	the reign of divine Science and the fulfillment of the Bible’s divine design, bringing in the millennium	God’s consciousness of itself (capitalized terms)

References to “The Thousand-year Periods”:**Books by Max Kappeler:**

The Bible in the Light of Christian Science, Vol. I: Genesis, pp. 13–16; more fully, Vols. I–V).

The Four Levels of Spiritual Consciousness: Science itself, divine Science, absolute Christian Science, Christian Science, pp. 29–32, 44–62.

The Minor Prophets in the Light of Christian Science, pp. 1–12.

The Seven Synonyms for God, chapter 2: the seven 1000-year periods; and chapter 10: symbol and reality.

Recordings by Max Kappeler:

A-6III: *Syllabus III*, Class, 1978 – Wilmington, (DE), hour 16.

A-6V: *Syllabus V*, Class, 1980, hours 1–2.

B-2: *From Atomistic Thinking to Cybernetic Comprehensive Consciousness*, Class, 1970 – Ogunquit, (ME), hour 3.

C-1G: *CH. XV, Genesis, The Structure of the Christian Science Textbook—Our Way of Life*, Series of Talks: 1981, hours 21–24 (also listed separately as M-13).

D-1 *The 4 Levels of Science*, Series of Talks 1967/68 – London, England, hours 3–6A, 9, 17, (from 5th, to 6th, to 7th 1000-year periods).

M-13: *The 1000-year periods in Biblical History Found in “The Minor Prophets” in the Bible*, four hours from C-1G (#21–24).

M-18: *Symbol and Reality: Evolving through the 1000-year periods in the Bible*, 1 hour.

Books by John Doorly:

Christian Science Practice, pp. 29–30, 301–304.

God and Science—Symbols and their importance, Publisher: London, F. Muller [©1949], pp. 66–69; more generally, pp. 58–70.

Talks on the Science of the Bible, Vol. I “red-book,” pp. 36–37, 52–53, 117–119, 128–130, 132–133, 135–139.

Talks on the Science of the Bible, Vol. II “red-book,” pp. 355–356, 363–368 (symbol and reality); statement, pp. 14–15.

Talks at the Oxford Summer School, 1948, Vol. I, pp. 29–31.

Talks at the Oxford Summer School, 1949, Vol. II, pp. 163–164.

Overview of “Genesis” (S&H Chapter XV) in Light of the 7 Synonymous Terms¹

	<i>Days of Creation (1st Record – Part I)</i>	<i>Adam-Story (2nd Record – Part II)</i>	<i>1000-Year Periods (Part III)</i>
Mind	1. light—intelligence, creative power	1. mist—ignorance	1. Adam-record of creation, Adam to Enoch—awakening (c. 4000–3000 BC)
Spirit	2. firmament—onliness of spiritual reality, separates real from unreal, understanding	2. Adam formed of dust and breath, 2 trees—duality, impurity	2. Noah—turning away from material beliefs, purity, understanding (c. 3000–2000 BC)
Soul	3. dry land, seed within itself—definiteness of spiritual identity, which defines all things rightly	3. Adam in garden (body), names every creature, no helpmeet—corporeal identity, false identification	3. Abraham, Isaac, Jacob, Joseph, Moses, Joshua, Judges—going the way from sense to Soul (c. 2000–1000 BC)
Principle	4. sun, moon, stars—Principle’s system governing the universe; scientific metaphysics demonstrating spiritual power	4. deep sleep of Adam, Eve made from his rib, the misinterpretation of the serpent—mesmerism, division, atomism	4. Samuel, kings, prophets—true government through prophecy; Principle’s system interpreting itself and governing the universe (c. 1000 BC–1 AD)
Life	5. teeming, abundant fish and fowl (soaring in the firmament)—fullness, multiplication, exaltation of spiritual life	5. serpent tempts Eve, who eats from tree of good and evil; nakedness—demoralization, downfall, lack	5. Jesus, the apostles, Paul, the spreading of Christianity, Revelation—laying down a mortal sense of life for newness of Life as Spirit (c. 1–1000 AD)
Truth	6. every living creature: animals and man—spiritual consciousness, spiritual manhood and dominion	6. Eve cursed, Adam cursed to till the ground, Cain kills Abel—mortal manhood, error self-destroyed	6. pioneering scientific consciousness, understanding being through scientific methods (vs. blind faith) (c. 1000–2000 AD)
Love	7. creation finished, rest—fulfillment, peace, the perfection of integrated being	7. Cain flees from God’s presence and dwells in Nod—error excluded as nothingness	7. reign of divine Science, fulfillment of the Bible’s design, bringing in the millennium (2000 AD onwards)

¹ This diagram is illustrative material from Kappeler’s “*CH. XV, Genesis, The Structure of the Christian Science Textbook—Our Way of Life*” (Tapecode C-1G). For additional study see references to the previous diagram, “The Thousand-Year Periods.”

**Days of Creation—Numerals of Infinity
(S&H 520:10)**

<i>days of creation</i>	<i>numerals of infinity</i>	<i>synonyms for God</i>
creator beginning wisdom guides, leads, steers	All idea intelligence power law	Mind
separates development purity birth	substance order the Only only good reality understanding	Spirit
resurrection transformation rebukes from sense to Soul balance	identity incorporeal rule	Soul
proves demonstrates obedience teaches practice	Science system governs harmoniously foundational absolute	Principle
multiplication supply exaltation inspiration love	omnipresence isness infinite individuality immortality eternity	Life
health affirms dominion alternative	the whole idea the complete form divine consciousness ideal	Truth
fulfillment holiness protects rest	perfection universal plan glory	Love

References for the Days of Creation—Numerals of Infinity (S&H 520:10)

Books by Max Kappeler:

Complete Compendium for the Study of Christian Science, p. 45.

The Seven Synonyms for God, chapter 2: the order of the seven days, also chapter 6: the Word-order.

Recordings by Max Kappeler:

A-6III: *Syllabus III, 1978* – Wilmington, (DE), hours 26–27.

B-2: *From Atomistic Thinking to Cybernetic Comprehensive Consciousness*, Class, 1970 – Ogunquit, (ME), hours 2–5.

C-1G: *CH. XV, Genesis, The Structure of the Christian Science Textbook—Our Way of Life*, Series of Talks: 1981, hours 13B–14A.

M-33: *The Days of Creation Become the Numerals of Infinity*, (4 hours from B-2, #2–5).

Books by John Doorly:

God and Science—Symbols and their importance, Publisher: London, F. Muller [©1949], statement pp. 15–16, 41–48, Appendix I, pp. 216–218.

The Pure Science of Christian Science, pp. 18–19, 47–48.

Talks on the Science of the Bible, Vol. I “red-book,” pp. 59–61, 63–65, 80–83, 155–157, 272–274.

Talks on the Science of the Bible, Vol. II “red-book,” pp. 54–55.

Talks at the Oxford Summer School, 1948, Vol. I, p. 20.

Talks at the Oxford Summer School, 1949, Vol. II, pp. 136–137, 145–146, 148–151, 156–157.

The numerals of infinity, called seven days
(S&H 520:10)

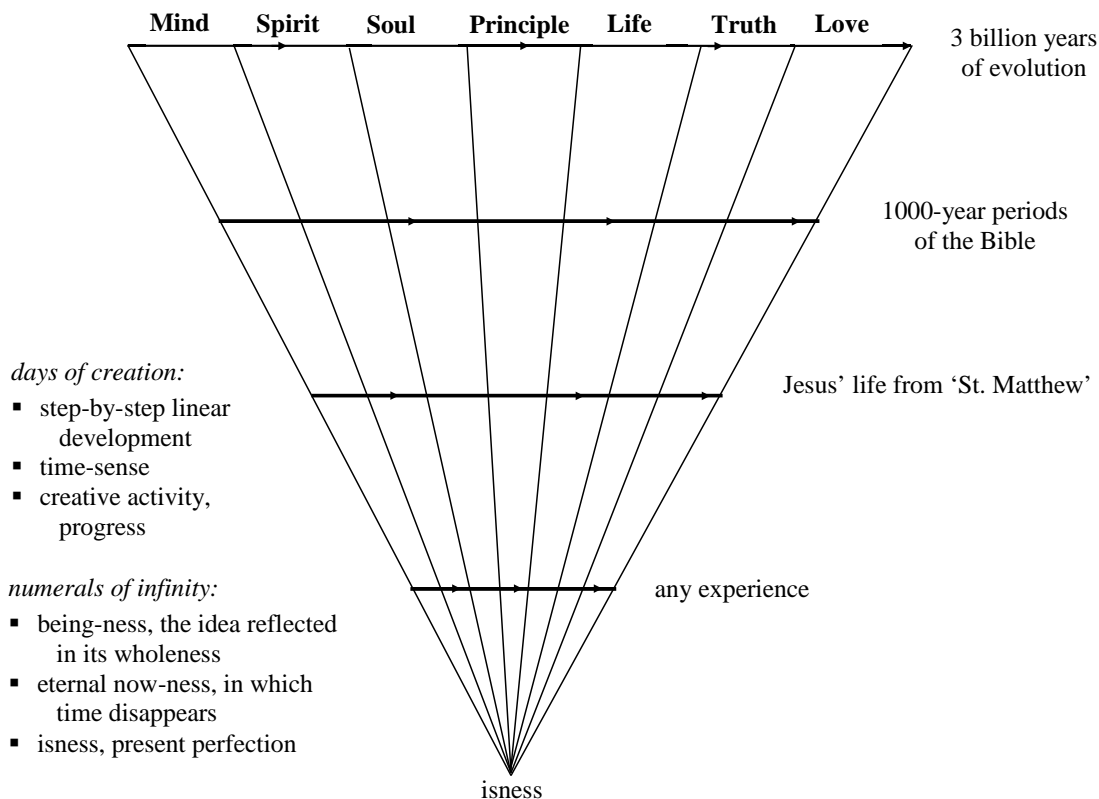

References

Books by Max Kappeler:

Complete Compendium for the Study of Christian Science, p. 44.

The Seven Synonyms for God, chapter 2: the order of the seven days, also chapter 6: the Word-order.

Recordings by Max Kappeler:

A-6III: *Syllabus III, 1978* – Wilmington, (DE), hours 8–10, 26–27.

B-2: *From Atomistic Thinking to Cybernetic Comprehensive Consciousness*, Class, 1970 – Ogunquit, (ME), hours 2–5.

C-1G: *CH. XV, Genesis, The Structure of the Christian Science Textbook—Our Way of Life*, Series of Talks: 1981, hours 13B–14A.

G-2: *The Science of Being—As I See It Today*, Lecture, 1970 – London, England, hours 2B–3.

Books by John Doorly:

God and Science—Symbols and their importance, Publisher: London, F. Muller [©1949], statement pp. 15–16, 41–48, Appendix I, pp. 216–218.

The Pure Science of Christian Science, pp. 18–19, 47–48.

Talks on the Science of the Bible, Vol. I “red-book,” pp. 59–61, 63–65, 80–83, 155–157, 259–260, 272–274.

Talks on the Science of the Bible, Vol. II “red-book,” pp. 54–55.

Talks at the Oxford Summer School, 1948, Vol. I, p. 20.

Talks at the Oxford Summer School, 1949, Vol. II, pp. 136–137, 145–146, 148–151, 156–157.

Books by Joel Jessen:

From the Physical, Through the Mental, To the Spiritual, p. 54.

The seven synonymous terms for God
The blending of ideas

diagram A

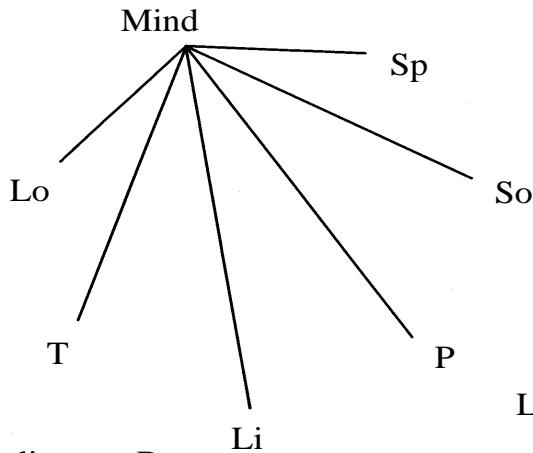

diagram B

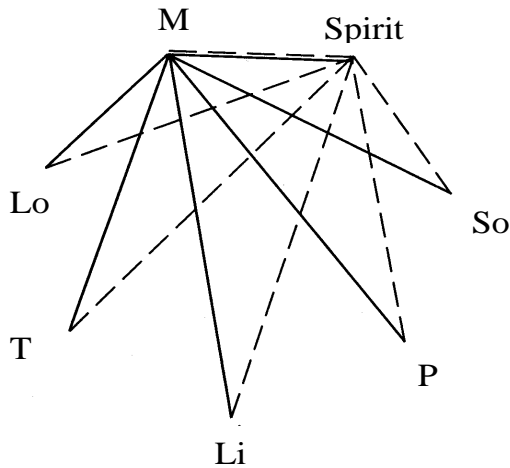
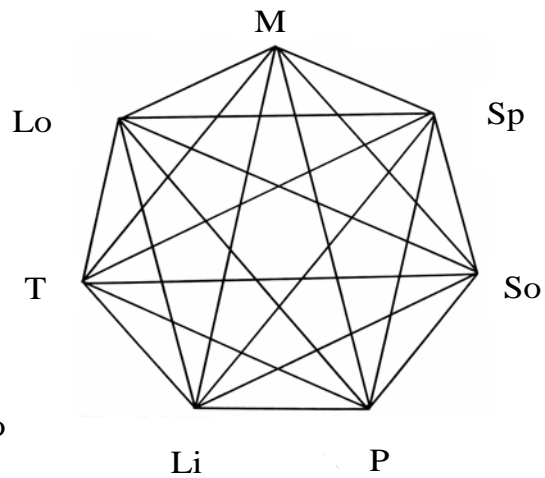

diagram C



References:

Books by Max Kappeler:

The Seven Synonyms for God, chapter 3.

Why study Christian Science as a Science?, pp. 20–23.

Books by John Doorly:

Talks on the Science of the Bible, Vol. I “red-book,” pp. 61–62, 114–115.

Recordings by Max Kappeler:

A-6II: *Syllabus II*, 1977 – Wilmington, (DE), the whole set, but especially hours 4–15.

A-4: *The Structure-principle of Being: our need for a divine system of reference*, Class 1974 – Wilmington, (DE), hours 12–13.

A-5: *A Seminar on the 7 Synonymous Terms for God*, Seminar 1975, Wilmington, (DE), hours 10–15, 18.

B-2: *From Atomistic Thinking to Cybernetic Comprehensive Consciousness*, Class, 1970 – Ogunquit, (ME), hours 4–5.

G-2: *The Science of Being—As I See It Today*, Lecture, 1970 – London, England, hour 3.

The Seven Synonyms for God Their Sevenfold Reflection

Synonyms	Mind	Spirit	Soul	Principle	Life	Truth	Love
Mind	M /M	Sp /M	So /M	P /M	Li /M	T /M	Lo /M
Spirit	M /Sp	Sp /Sp	So /Sp	P /Sp	Li /Sp	T /Sp	Lo /Sp
Soul	M /So	Sp /So	So /So	P /So	Li /So	T /So	Lo /So
Principle	M /P	Sp /P	So /P	P /P	Li /P	T /P	Lo /P
Life	M /Li	Sp /Li	So /Li	P /Li	Li /Li	T /Li	Lo /Li
Truth	M /T	Sp /T	So /T	P /T	Li /T	T /T	Lo /T
Love	M /Lo	Sp /Lo	So /Lo	P /Lo	Li /Lo	T /Lo	Lo /Lo

References:

Books by Max Kappeler:

Epitomes for the Spiritually Structured Interpretation of the Christian Science Textbook, 'Science of Being', pp. 3–6.
The Seven Synonyms for God, chapter 3.
From the Physical, Through the Mental, To the Spiritual, pp. 84–88.

Recordings by Max Kappeler:

A-6II: *Syllabus II*, 1977 – Wilmington, (DE), the whole set, but especially hours 4–15.
 A-5: *A Seminar on the 7 Synonymous Terms for God*, Seminar 1975, Wilmington, (DE), hours 10–15, 18.
 B-2: *From Atomistic Thinking to Cybernetic Comprehensive Consciousness*, Class, 1970 – Ogunquit, (ME), hours 4–5, 10B.
 C-1BI: *CH. X, Science of Being, Part I, The Structure of the Christian Science Textbook—Our Way of Life*, hours 17–24 (hours 4–11, if numbered from the beginning of the chapter).
 C-6: *Exercises in Culturing Consciousness According to the Matrix of Science and Health*, Class 1976 – Ilkley, England, hours 17–18 (also listed separately as X-10).
 E-2: *The Matrix of Immortality: Code of divine laws*, Class 1974 – Wilmington, (DE), hour 4 (7x7 matrices, e.g. 'Prayer').
 G-2: *The Science of Being—As I See It Today*, Max Kappeler, Lecture, 1970 – London, England, hour 5.
 X-10: *How Ideas Dissolve Illusions*, 3 cassettes from C-6 (hours 17–19).

Scientific Obstetrics (S&H 463:5–20)

forerunner: *mental self-knowledge (S&H 462:20–4)*

“Anatomy, when conceived of spiritually, is mental self-knowledge, and consists in the dissection of thoughts to discover their quality, and origin. Are thoughts divine or human? That is the important question ... It teaches the control of mad ambition. It unfolds the hallowed influences of unselfishness, philanthropy, spiritual love.”

spiritual birth:

Word: *how to bring forth an idea (thought)*

Mind “Teacher and student should also be familiar with the obstetrics taught by this science.”

Spirit “To attend properly the birth of the new child, or divine idea, you should so detach mortal thought from its material conceptions...”

Soul “...that the birth will be natural and safe.”

Christ: *the power of the idea to eliminate error (idea)*

Principle “Though gathering new energy, this idea cannot injure its useful surroundings in the travail of spiritual birth.”

Life “A spiritual idea has not a single element of error, and this truth removes properly whatever is offensive.”

Christianity: *the bigness of an idea (idea in the synonym for God)*

Truth “The new idea, conceived and born of Truth and Love, is clad in white garments. Its beginning will be meek, its growth sturdy, and its maturity undecaying. When this new birth takes place, the Christian Science infant is born of the Spirit, born of God...”

Science: *the synonym for God alone is Being (there is only the synonym for God)*

Love “...and can cause the mother no more suffering. By this we know that Truth is here and has fulfilled its perfect work.

References:

Books by Max Kappeler:

'The Psychology of Spirit', No. 9 – (booklet)

'Scientific Obstetrics', No. 1 - (booklet)

The Seven Synonyms for God, chapter 3.

Recordings by Max Kappeler:

A-6V: *Syllabus V*, 1980, Wilmington, (DE), hour 2.

E-1: *The Structure of Being and its Universal Laws*, Class, 1973 – New York, hour 39.

X-11: *Scientific Obstetrics: Giving birth to the idea*, 1977, Wilmington, (DE), 2 hours.

Books by John Doorly:

Talks on the Science of the Bible, Vol. IX “red-book,” pp. 387–391.

Talks at the Oxford Summer School, 1948, Vol. I, pp. 12–15.

Talks at the Oxford Summer School, 1948, Vol. II, pp. 41–42, 252–253.

Talks at the Oxford Summer School, 1949, Vol. I, pp. 14–18, 71–74.

Talks at the Oxford Summer School, 1949, Vol. II, pp. 171–177; Nicodemus and the new birth: pp. 152–154.

“ANIMAL MAGNETISM – UNMASKED”

(Development of the subject through the various revisions of *Science and Health with Key to the Scriptures* by Mary Baker Eddy)

Miscellaneous Writings, pp. 222:29–5; *Retrospection and Introspection*, pp. 37:21–38:26, by Mary Baker Eddy

1 st Edition (1875) MIND	No special chapter. The subject was treated in the chapter “Healing the Sick” (16 pages). Accent lies on observation, investigation, inquiring, gaining insight into the subject of mesmerism.
2 nd Edition (1878) SPIRIT	Title of chapter: Mesmerism: (15 pages) Accent is on distinguishing between metaphysics and mesmerism, between “mind” and “Divine mind”.
3 rd Edition SOUL	Title of chapter: “Demonology” (46 pages). Accent is on the malicious abuse of mesmerism, on the <i>modus operandi</i> of malicious malpractice. Now uses “Mind” capitalized. Basis of malpractice is animal nature.
6 th Edition (1883) PRINCIPLE	Title of chapter: “Demonology” (12 pages). Accent is on impersonalizing animal magnetism.
16 th Edition (1886) LIFE	Title of chapter: “Animal Magnetism” (13 pages). Accent is on dragon’s warfare against the woman, animal magnetism warring with the divine idea. Without a knowledge of animal magnetism, error continues and increases. 1886–91 Department on “Animal Magnetism” in Journal 1887 “Ways that are vain: (<i>Miscellany</i> , by Mary Baker Eddy, pp. 210–213)—was not put into Prose Works by Mrs. Eddy. 1889 “Malicious Animal Magnetism” (Christian Science Journal, February). 1890 “A Card” (Christian Science Journal, August).
50 th Edition (1891) TRUTH	Title of chapter: “Animal Magnetism” (7 pages) Text similar to final edition. Dropped all of those passages referring to the struggle and warfare. Accent is on “doing right” which excludes animal magnetism. Evil is no power, no reality, only a belief—belief has not one quality of Truth. There is no transference of mortal thought and willpower. 1899 “What Our Leader Says” (<i>Miscellany</i> , by Mary Baker Eddy, p. 210). “Keep your mind filled with Truth and Love.”
226 th Edition (1902) LOVE	Title of chapter “Animal Magnetism” (7 pages) Accent is on the nothingness of animal magnetism <ul style="list-style-type: none"> ▪ evil is a suppositional lie ▪ the Allness of God, good, is the answer to animal magnetism. 1910 Title “Animal Magnetism Uncovered” 1910 Title “Animal Magnetism Unmasked” (a few months later)

References for further study of the previous chart, *Animal Magnetism – Unmasked*

Books by Max Kappeler

Animal Magnetism – Unmasked, pp. 47–81.

Recordings by Max Kappeler

A-6II: *Syllabus II*, 1977, hours 22–23.

B-2: *From Atomistic Thinking to Cybernetic Comprehensive Consciousness*, Class, 1970 – Ogunquit, (ME), hour 24.

C-1AN: *CH. V, Animal Magnetism – Unmasked, The Structure of the Christian Science Textbook—Our Way of Life*, hours 7B–8.

Books by John W. Doorly

Christian Science Practice, pp. 328–329, 344–346, 349–355.

Talks on the Science of the Bible, #70 “blue-book,” pp. 15–20.

Talks on the Science of the Bible, Vol. VI “red-book,” pp. 108–110, 231–232, 289–290.

Talks on the Science of the Bible, Vol. VIII “red-book,” pp. 13–15, 16–19, 42, 83–85, 283–289.

Books by Mary Baker Eddy

Miscellaneous Writings.

Miscellany.

Retrospection and Introspection.

Science and Health with Key to the Scriptures.

Healing **John Doorly's method of treatment**

1. The practitioner begins his treatment by putting the whole problem, including all the suggestions, behind him.
2. The practitioner turns to the infinite Mind.
3. The true identity of what is called a problem appears.
4. The true idea uncovers the governing error.
5. The specific error is compensated by the fullness of the specific truth.
6. The divine idea is omnipotent in the realm of Truth *and* in the realm of human belief.
7. Every Christian Science treatment blesses.

References:

Books by Max Kappeler:

The Development of the Christian Science Idea and Practice
©2004, 2nd edition, pp. 71–84.

Recordings by Max Kappeler:

D-1: *The 4 Levels of Science*, Series of Talks 1967/68 – London, England, hour 24A.

Books by John Doorly:

Christian Science Practice, pp. 78–79.

Talks on the Science of the Bible, Vol. VIII, “red-book,” pp. 199–202.

References for the subject of healing in general:

The development of the healing practice:

Books by Max Kappeler:

The Development of the Christian Science Idea and Practice ©2004, 2nd edition, pp. 19–67.

Recordings by Max Kappeler:

D-1: *The 4 Levels of Science*, Series of Talks 1967/68 – London, England, hours 21–23.

Healing on the levels of Science:

Books by Max Kappeler:

The Development of the Christian Science Idea and Practice ©2004, 2nd edition, pp. 62–96.

The Four Levels of Spiritual Consciousness: Science itself, divine Science, absolute Christian Science, Christian Science, pp. 86–87.

Recordings by Max Kappeler:

B-3: *Christian Science Practice: Based on the Science of divine revelation*, Class 1976, Wilmington, (DE), hours 16–18.

D-1: *The 4 Levels of Science*, Series of Talks 1967/68 – London, England, hour 24.

D-2: *Divine Cybernetics: The proto-science, the integral Science*, Class, 1969 – Braunwald, Switzerland, hours 8–10.

M-36: *Healing on the Levels of absolute Christian Science, divine Science and Science itself*, 3 hours from B-3 (#16–18).

Healing in the sixteen chapters of the Textbook in Matrix-form:

Recordings by Max Kappeler:

B-3: *Christian Science Practice: Based on the Science of divine revelation*, Class 1976, Wilmington, (DE), hours 11–15.

C-6: *Exercises in Culturing Consciousness According to the Matrix of the Science and Health*, Class 1976 – Ilkley, England, hours 12–16.

M-35: *Healing in the 16 Chapters of the Christian Science Textbook*, Class 1976, Wilmington, (DE), 5 hours from B-3 (#11–15).

Christian Science Practice

	Practitioner			Patient
	<i>Love and Mind</i>	<i>Truth and Mind</i>	<i>Life and Soul</i>	<i>Love } and Spirit</i> <i>Truth } and Spirit</i> <i>Life } and Spirit</i> <i>Healing process</i>
	<i>How he himself must be</i>	<i>The Truth he knows</i>	<i>The practitioner's Method</i>	
Mind	seeing only perfection	Mind is all	law of Mind	<i>Love + Spirit</i> based on Mind-science
Spirit	good and pure	Spirit is the only reality	Spirit: the only substance	creates order
Soul	selfless	incorporeality and sinlessness of man	rule of Soul: supremacy;	<i>Truth + Spirit</i> translation takes place
Principle	winning his own pardon scientifically	Science and metaphysics: basis of demonstration	government: omnipotence of Principle	reaching every part of the system
Life	experiencing fullness of life; laying down the mortal concept	man maintained by fullness of Life	immortality: self-supporting Life	renewal of Life <i>Life + Spirit</i> eternal life
Truth	growing into Christian manhood	man's dominion through consciousness	form of man: consciousness of Truth	perfect health
Love	anticipating fulfillment	man's perfection; no penalty	fulfillment: perfection of Love	solution for every problem

References: Books by Max Kappeler:

Epitomes for the Spiritually Structured Interpretation of the Christian Science Textbook, pp. 2–10.
The Science of the Oneness of Being in the Christian Science Textbook, pp. 183–196.
The Structure of the Christian Science Textbook, Vol. I, pp. 116–135.

Books by John Doorly:

Christian Science Practice

Recordings by Max Kappeler:

A-4: *The Structure-principle of Being: Our need for a divine system of reference*, Class, 1974, Wilmington, (DE), hours 24–25.
 C-6: *Exercises in Culturing Consciousness According to the Matrix of Science and Health*, Class 1976 – Ilkley, England
 C-1P: *CH. XII, Christian Science Practice, The Structure of the Christian Science Textbook—Our Way of Life*, 17 hours.

Category II

The fourfold operational sense of Being: Word, Christ, Christianity, Science

The Word-order

When John Doorly undertook his meticulous research of the synonyms for God in 1938/39, he followed the sequence of *Mind, Spirit, Soul, Principle, Life, Truth, Love* as given on page 465 of the Textbook, *Science and Health with Key to the Scriptures*, by Mary Baker Eddy. These seven synonyms define the nature, essence and wholeness of God. In the course of further study it was seen that this order of the seven synonyms for God is not a casual one, that they are not arranged in an arbitrary way. Quite the reverse. It is the only order possible if the *Word* of God or the Logos is to be defined. There are 5,040 possibilities of arranging all the seven synonyms in sequence, but Mary Baker Eddy could put them in only one order when the purpose of the order is to bring out the aspect of the *creative* Word of God. This Word-order shows the spiritual flow from the creative Mind up to its fulfillment in Love, thus symbolizing also the unchanging order of the seven days of creation.

The Christ-order

Though the discovery of the meaning of the Word-order and its far-reaching implications for any creative activity was overwhelming, an honest investigation of the synonyms for God could not overlook the fact that there are other orders of the seven synonyms in the Textbook. For instance, in “scientific translation of immortal Mind” on page 115 of “*Science and Health*” we find the order of divine *Principle, Life, Truth, Love, Soul, Spirit, Mind* defining the *Christ* in its office of *translating* God to the point of idea. As this order illustrates a different purpose from that of the Word, the synonyms for God are arranged in a different order. Again we become aware that in a structural concept it is not the facts (The synonyms per se) which are super-important but rather the relationships, the order, which exists between the facts. The office of the Christ is to translate God, the divine Principle which is Life, Truth, and Love, through Soul and Spirit to the point of manifesting God as perfect idea in Mind. Whenever the argument comes up in our consciousness that God does not come to a specific situation, we can counteract this argument of the anti-Christ by the understanding that the self-operative Principle which is the all-impelling Life, the ever-effective Truth and the ever-saving Love exchanges through Soul the false testimony of the material senses, thereby cleansing every situation through the onliness and purity of Spirit, so that only that which is of the nature of idea is manifested as the presence of the All-Mind. You can just feel the terrific power of this translation-order, sweeping away all that would obstruct the divine manifestation.

The Christianity-order

Again, on page 587 of “*Science and Health*” the term God is described in a different order, to bring out the *Christianity* sense. Here the order is *Principle; Mind; Soul; Spirit; Life; Truth;*

Love, depicting Principle, God's *reflection* as Principle's universe. The focus is on idea and this order answers the question: How big is a spiritual idea? It is always an idea of Principle in the universe of Mind, fully identified with this Principle through Soul-sense, thereby reflecting in Spirit all other idea, thus being father (Life), son (Truth), and mother (Love) to the whole universe. Here the order serves to establish the full-reflection of God's ideas.

The Science-order

These three orders are the only ones in which all the seven synonymous terms appear together in the Textbook. John Doorly naturally felt that there should be a fourth, for *Science*, because the holy city has four sides, which Mrs. Eddy interpreted as Word, Christ, Christianity, and Science. Praying about it, he could see that Being is not linear, but structural, so that the Word-order, when seen structurally, is founded on Principle, the middle term of the seven synonyms. Principle is based on the divine nature of Mind, Spirit, Soul, and demonstrated in its essence as Life, Truth, and Love. This reminded him of the symbol of the seven-branched candlestick. The seven lamps are not connected with one another in a linear sequential way but related through structure. This is very typical of Science: linear sequence, when understood in its isness becomes structural being.

Therefore, if you look at the Word-order of Mind, Spirit, Soul, Principle, Life, Truth, Love, not as linear arrangement but from the center, the shaft (Principle), you get a structural understanding of the synonyms for God. Next to *Principle*, are *Soul and Life*, then *Spirit and Truth*, and finally *Mind and Love*, connected in pairs, all resting on the central shaft of *Principle*.

The Development from Word to Science

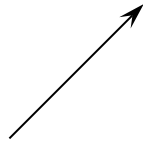

Word
(line)

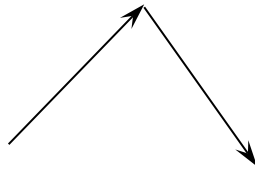

Christ
(plane)

“Christian Science translates Mind, God to mortals. It is the infinite calculus defining the line, plane, space, and fourth dimension of Spirit” (Mis. 22:10).

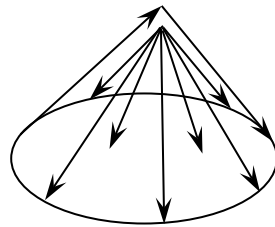

Christianity
(space)

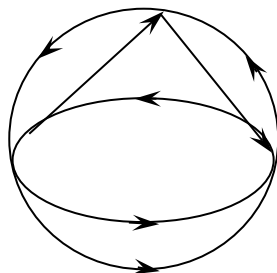

Science
(4th dimension)

References:

Books by Max Kappeler:

The Four Levels of Spiritual Consciousness: Science itself, divine Science, absolute Christian Science, Christian Science, pp. 87–89 (4 on levels, pp. 90–117).

Recordings by Max Kappeler:

A-6IV: *Syllabus IV*, 1979, Wilmington, (DE), hours 1–3 (also listed separately as M-29).

B-2: *From Atomistic Thinking to Cybernetic Comprehensive Consciousness*, Class, 1970 – Ogunquit, (ME), hour 7.

D-4: *Divine Cybernetics and the Self-operating “Dimensional Laws” of the One Being, God*, Series of talks 1971/72 – New York, hours 2B–3A, 17, 22A.

G-2: *The Science of Being—As I See it Today*, Max Kappeler, Lecture, 1970 – London, England, hour 3.

M-29: *Examples of the 4-fold Operation: Word, Christ, Christianity, Science*, 3 hours from Syllabus IV (#1–3).

Books by John Doorly:

Talks on the Science of the Bible, Vol. II, “red-book,” pp. 218–219 (Word and Christ only: angels ascending and descending).

The self-operation of Being

<i>symbol</i>	<i>Word</i>	<i>Christ</i>	<i>Christianity</i>	<i>Science</i>
holy city S&H 575:7–577:31	Word of Life, Truth, Love (Logos)	Christ, spiritual idea of God	Christianity, the outcome of the divine Principle of the Christ-idea in Christian history	Christian Science, which today and forever interprets this great example and Exemplar
S&H 465:9	incorporeal	divine	supreme	infinite
S&H 587:19	omnipotence	omniscience	omnipresence	omni-action
cardinal points S&H 575:26–576:2	north	east	south	west
(Doorly)	revelation	translation	reflection	interpretation
(Doorly)	seeking	finding	using	being
our universal life- principle:	choosing the right guiding principle	submitting ourselves to this principle and trusting its power of salvation	acting in accordance with this principle	understanding the Principle of being to be the guiding Principle of all life
self-operation of Being:	self-declaration	self-manifestation	self-fulfillment	self-explanation
God operates	out of itself	through itself	as itself	to and for itself
cybernetic system	input	process	output	feedback
God/man relationship	man's relationship to God	God's relationship to man	man's relationship to man	Principle and idea is one
Bible	Law	prophets	Jesus Christ	'Science & Health'
Gospels	Matthew	Mark	Luke	John

References for the previous illustration, *The self-operation of Being*

Books by Max Kappeler

Introduction to the Science of Christian Science, pp.13–25 (the whole book presents an exposition of the Science of Christian Science through the fourfold operation).

The Four Levels of Spiritual Consciousness: Science itself, divine Science, absolute Christian Science, Christian Science, pp. 4–9, 87–89, 90–117 (4 on levels).

The Science of the Oneness of Being in the Christian Science Textbook, pp. 45–57.

Recordings by Max Kappeler

- A-I: *An Introduction to the Science of Christian Science*, Class, 1962, Zürich, Switzerland, hours 1–2A.
- A-4: *The Structure-principle of Being: Our need for a divine system of reference*, Class 1974 – Wilmington, (DE), hour 14.
- A-6IV: *Syllabus IV*, 1979 – Wilmington, (DE)/Elizabethtown, (PA), hours 1–3 (also listed separately as M-29).
- B-2: *From Atomistic Thinking to Cybernetic Comprehensive Consciousness*, Class, 1970 – Ogunquit, (ME), hours 7–8.
- D-4: *Divine Cybernetics and the Self-operating “Dimensional Laws” of the One Being, God*, Series of talks 1971/72 – New York, hours 2B–3A.
- M-29: *Examples of the 4-fold Operation: Word, Christ, Christianity, Science*, 3 hours from Syllabus IV (#1–3).

Books by John W. Doorly

Christian Science Practice, pp. 60–61, 209–210.

God and Science—Symbols and their importance, Publisher: London, F. Muller, ©1949, pp. 49–57.

Talks at the Oxford Summer School, 1948, Vol. I, pp. 75–78, 213.

Talks at the Oxford Summer School, 1948, Vol. II, pp. 145, 250–252.

Talks at the Oxford Summer School, 1949, Vol. I, pp. 166–167.

Talks on the Science of the Bible, Vol. I, “red-book,” pp. 37–38.

Talks on the Science of the Bible, Vol. IX, “red-book,” pp. 98, 135, 158–159.

Talks on the Science of the Bible, #58 “blue-book,” p. 31.

Talks on the Science of the Bible, #59 “blue-book,” pp. 31–32.

The Pure Science of Christian Science, pp. 20–29, 65–67, 127–153, 190–231.

The Four Bible Teachings

	Word
<i>as Word:</i>	7 days of creation <ul style="list-style-type: none"> ▪ the order of creative thought
<i>as Christ:</i>	7 statements of the Commandments <ul style="list-style-type: none"> ▪ the demands made on the thinker
<i>as Christianity:</i>	7 Beatitudes <ul style="list-style-type: none"> ▪ the seeker’s reward for a spiritual attitude
<i>as Science:</i>	7 statements of the Lord’s Prayer <ul style="list-style-type: none"> ▪ the fundamental facts of being

References / Recordings by Max Kappeler:

E-2: *The Matrix of Immortality: Code of divine laws*, Class 1974 – Wilmington, (DE), hour 9B.

Mind

	<i>Bible teaching</i>	<i>spiritual meaning</i>
Word as Word	first day: Genesis 1:3–5 “And God said, Let there be light: and there was light.” (Genesis 1:3)	is always saying to the seeking thought: Let there be light, intelligence, wisdom.
Word as Christ	first Commandment: “And God spake all these words, saying , I am the Lord thy God, which have brought thee out of the land of Egypt, out of the house of bondage.” (Exodus 20:1,2)	this intelligence leads out of the beliefs of mortal mind.
Word as Christianity	first Beatitude: “Blessed are the poor in spirit: for their’s is the kingdom of heaven.” (Matthew 5:3)	and promises the kingdom of heaven, the kingdom of divine ideas, to all who cultivate this seeking consciousness.
Word as Science	first stanza of the “Lord’s Prayer”: “Our Father which art in heaven, <i>Our Father-Mother God, all-harmonious.</i> ” (S&H 16:26–27)	until they realize that they have forever existed as idea in the all-harmonious parent Mind.

Spirit

<i>Bible teaching</i>		<i>spiritual meaning</i>
Word as Word	second day: Genesis 1:6–8 “And God said, Let there be a firmament in the midst of the waters, and let it divide the waters from the waters.” (Genesis 1:6)	separates good from evil, illusions from ideas
Word as Christ	second Commandment: “Thou shalt have no other gods before me.” (Exodus 20:3)	and demands acknowledgment of the one and only idea, which is reflected in ideas
Word as Christianity	second Beatitude: “Blessed are they that mourn: for they shall be comforted.” (Matthew 5:4)	comforts with the substance of reality those who separate themselves from long- cherished beliefs
Word as Science	second stanza of the “Lord’s Prayer”: “Hallowed be thy name. <i>Adorable One.</i> ” (S&H 16:28–29)	and brings the realization that Spirit is the one and only reality

Soul

<i>Bible teaching</i>		<i>spiritual meaning</i>
Word as Word	third day: Genesis 1:9–13 “And God said, Let the waters under the heaven be gathered together unto one place, and let the dry land appear, and it was so.” (Genesis 1:9)	brings out the identity of every idea
Word as Christ	third Commandment: “Thou shalt not make unto thee any graven image, nor any likeness of any thing that is in the heaven above, or that is in the earth beneath, or that is in the water under the earth.” (Exodus 20:4)	and demands that we should not set up any false concepts or models
Word as Christianity	third Beatitude: “Blessed are the meek: for they shall inherit the earth.” (Matthew 5:5)	but meekly identify ourselves with the one Ego
Word as Science	third stanza of the “Lord’s Prayer”: “Thy kingdom come. <i>Thy kingdom is come; Thou art ever-present.</i> ” (S&H 16:30–31)	and thereby recognize that the kingdom of God is within us and ever-present

Principle

	<i>Bible teaching</i>	<i>spiritual meaning</i>
Word as Word	fourth day: Genesis 1:14–9 “And God said, Let there be lights in the firmament of heaven to divide the day from the night; and let them be for signs, and for seasons and for days, and years.” (Genesis 1:14)	governs all identities harmoniously and includes them in a coherent system
Word as Christ	fourth Commandment: “And shewing mercy unto thousands of them that love me, and keep my commandments.” (Exodus 20:6)	obedience to Principle brings demonstration
Word as Christianity	fourth Beatitude: “Blessed are they which do hunger and thirst after righteousness: for they shall be fulfilled.” (Matthew 5:6)	so that loyalty and consecration are rewarded
Word as Science	fourth stanza of the “Lord’s Prayer”: “Thy will be done in earth, as it is in heaven. <i>Enable us to know, — as in heaven so on earth, — God is omnipotent, supreme.</i> ” (S&H 171–3)	and we recognize that divine Principle is omnipotent both in the absolute (heaven) and the relative (earth)

Life

	<i>Bible teaching</i>	<i>spiritual meaning</i>
Word as Word	fifth day: Genesis 1:20–23 “And God said, “Let the waters bring forth abundantly the moving creature that hath life, and fowl that may fly above the earth in the open firmament of heaven.” (Genesis 1:20)	reveals itself through exalted ideas which soar above corporeality and confinement and are available in abundance
Word as Christ	fifth Commandment: “Thou shalt not take the name of the Lord thy God in vain; for the Lord will not hold him guiltless that taketh his name in vain.” (Exodus 20:7)	these exalted ideas forever express God’s nature anew and are not empty concepts
Word as Christianity	fifth Beatitude: “Blessed are the merciful; for they shall obtain mercy.” (Matthew 5:7)	they illumine creation with the true scientific concept only
Word as Science	fifth stanza of the “Lord’s Prayer”: “Give us this day our daily bread; <i>Give us grace for today; feed the famished affections;</i> ” (S&H 17:4–5)	and thus become the bread of Life which sustains man’s being

Truth

<i>Bible teaching</i>	<i>spiritual meaning</i>
<p>Word as Word</p> <p>sixth day: Genesis 1:24–31</p> <p>“And God said, Let us make man in our image, after our likeness: and let them have dominion over the fish of the sea, and over the fowl of the air, and over the cattle, and over every living thing that creepeth upon the earth.” (Genesis 1:26)</p>	<p>is divine consciousness, including all ideas (man), and has dominion over everything</p>
<p>Word as Christ</p> <p>sixth Commandment:</p> <p>“Remember the sabbath day to keep it holy. Six days shalt thou labour, and do all thy work.” (Exodus 20:8,9)</p>	<p>these ideas must be understood and realized, until all false beliefs fade</p>
<p>Word as Christianity</p> <p>sixth Beatitude:</p> <p>“Blessed are the pure in heart: for they shall see God.” (Matthew 5:8)</p>	<p>and the pure consciousness of God is seen</p>
<p>Word as Science</p> <p>sixth stanza of the “Lord’s Prayer”:</p> <p>“And forgive us our debts, as we forgive our debtors. <i>And Love is reflected in love,</i>” (S&H 17:6–7)</p>	<p>man then knows himself as guiltless (sinless) as the pure reflection of God</p>

Love

<i>Bible teaching</i>		<i>spiritual meaning</i>
Word as Word	<p>seventh day: Genesis 2:1, 2</p> <p>“And on the seventh day God ended his work which he had made; and he rested on the seventh day from all his work which he had made.” (Genesis 2:2)</p>	rests in fulfillment and completion
Word as Christ	<p>seventh Commandment:</p> <p>“But the seventh day is the sabbath of the Lord thy God: in it thou shalt not do any work, thou, nor thy son, nor thy daughter, thy manservant, nor thy maidservant, nor thy cattle, nor thy stranger that is within thy gates: For in six days the Lord made heaven and earth, the sea, and all that in them is, and rested the seventh day; wherefore the Lord blessed the sabbath day and hallowed it.” (Exodus 20:10, 11)</p>	all problems are solved
Word as Christianity	<p>seventh Beatitude:</p> <p>“Blessed are the peacemakers: for they shall be called the children of God.” (Matthew 5:9)</p>	the peace of the children of God is attained
Word as Science	<p>seventh of Lord’s Prayer:</p> <p>“And lead us not into temptation, but deliver us from evil: (S&H 17:8–11)</p>	salvation is an inescapable fact

References to the previous chart covering the Bible teaching and spiritual meaning of the seven synonymous terms:

Books by Max Kappeler:

Complete Compendium for the Study of Christian Science, # 3, p. 87

The Seven Synonyms for God, chapter 2.

Books by John Doorly:

Talks at the Oxford Summer School, 1948, Vol. II, pp. 248–250.

Talks on the Science of the Bible, Vol. I “red-book,” pp. 130–134, 139–140, 148, 152–153, 159–160, 175–176, 181–182.

The Pure Science of Christian Science, pp. 94–97.

Recordings by Max Kappeler:

A-6III: *Syllabus III*, 1978, Wilmington, (DE), hours 17–20.

M-27: “*The Lord’s Prayer*”: *Considered according to the 7 synonyms for God interwoven with the 4-fold operation of Being*, 1 hour from C-2PR (#23).

**The four operating as the seven through divine order
(S&H 465:9-10)**

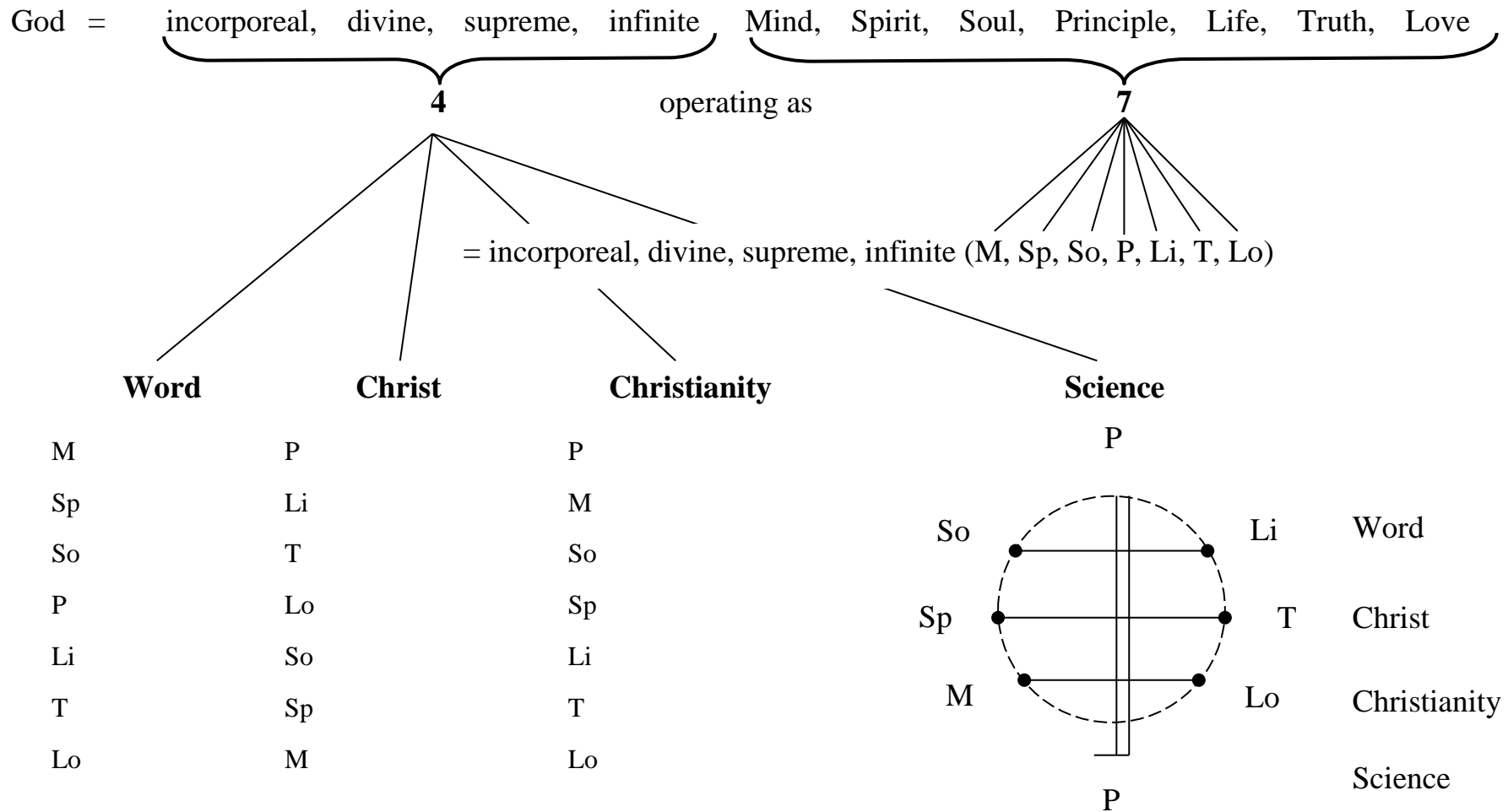

References for the previous diagram: ‘The four operating as the seven through divine order’

Books by Max Kappeler:

The Seven Synonyms for God, chapter 1, 2, 6.

Recordings by Max Kappeler:

G-2: *The Science of Being—As I See it Today*,
Max Kappeler, Lecture, 1970 – London,
England, hour 3.

Books by John Doorly:

Christian Science Practice, pp. 31–34, 45.

The Pure Science of Christian Science, pp. 49–51.

Talks at the Oxford Summer School, 1948, Vol. I, pp.
232–233 (the nature of divine order), also p. 255.

Talks on the Science of the Bible, Vol. II “red-book,”
pp. 393–394.

Talks on the Science of the Bible, Vol. VI “red-
book,” pp. 179–180, 205–206.

Talks on the Science of the Bible, Vol. IX “red-
book,” pp. 112–113 (4 orders), 127.

Examples of the four orders:

‘Prayer’: Word-order

Books by Max Kappeler:

The Structure of the Christian Science Textbook, pp. 10–15.

Epitomes for the Spiritually Structured Interpretation of the Christian Science Textbook,
pp. 2–4.

Recording by Max Kappeler:

C-1P: ‘Prayer’, 27 hours.

Joshua and Judges: each in the Word-order (7 x7)

Book by Max Kappeler:

The Bible in the Light of Christian Science, Vol. III: Joshua, Judges.

Book by John Doorly:

Talks on the Science of the Bible, Vol. IV “red-book”.

I and II Samuel: Word-order

Book by Max Kappeler:

The Bible in the Light of Christian Science, Vol. IV: I & II Samuel.

Book by John Doorly:

Talks on the Science of the Bible, Vol. V “red-book”.

*Note: The vast majority of texts in the Bible and in ‘Science and Health with key to the Scriptures’
are laid out in the Word-order, so examples abound.*

II Kings: Christ-order

Book by John Doorly:

Talks on the Science of the Bible, Vol. VI “red-book,” pp. 149–293.

Jeremiah: Christ-order

Book by Max Kappeler:

The Minor Prophets in the Light of Christian Science, pp. 178–181.

Book by John Doorly:

Talks at the Oxford Summer School, 1948, Vol. I, pp. 109–256.

Examples of the four orders (cont.):

Romans: Christ-order

Book by Max Kappeler:

The Epistles in the Light of Christian Science. pp. 45–60.

Recording by Max Kappeler:

A-6IV: *Syllabus IV*, 1979 – Wilmington, (DE), hour 11–17.

Isaiah: Word, Christ, Christianity orders

Books by John Doorly:

Talks on the Science of the Bible, No. 73 “blue book,” pp. 25–31.

Talks on the Science of the Bible, No. 74 “blue book,” pp. 1–21.

Daniel: Word Christ, Christianity, and Science orders

Book by Max Kappeler:

The Minor Prophets in the Light of Christian Science, pp. 185–188.

Book by John Doorly:

Talks on the Science of the Bible, Vol. IX “red-book,” pp. 157–188 (in full, pp. 15–188).

Zechariah: Word, Christ, Christianity, and Science orders

Book by Max Kappeler:

The Minor Prophets in the Light of Christian Science, pp. 140–159.

Book by John Doorly:

Talks on the Science of the Bible, Vol. IX “red-book,” pp. 314–386.

I John: Word, Christ, Christianity, and Science orders

Book by Max Kappeler:

The Epistles in the Light of Christian Science. pp. 212–221.

Examples of the Word-order

<i>Bible</i>	<i>days of creation</i> <i>spiritual meaning</i>	<i>3rd degree</i> (S&H 116)	<i>creativity</i> (Doorly)	<i>scientific tools</i> (Doorly)	<i>synonyms for God</i> (S&H 465)
light	intelligence	wisdom	creative ability	law	Mind
firmament	understanding	purity	unfoldment	order	Spirit
dry land, seed within itself	identity	spiritual understanding	identity	rule	Soul
lights: sun, moon, stars	system of ideas	spiritual power	classification	system	Principle
fish and fowl	fullness	love	individuality	method	Life
animals and man	true manhood	health	consciousness	form	Truth
creation finished	fulfillment	holiness	unity with God	plan or design	Love

References:

Books by Max Kappeler:

The Four Levels of Spiritual Consciousness: Science itself, divine Science, absolute Christian Science, Christian Science, pp. 181–187.
The Seven Synonyms for God, chapter 2.

Recordings by Max Kappeler:

A-4: *The Structure-principle of Being: Our need for a divine system of reference*, Class 1974
 Wilmington, (DE), hours 15–17.
 A-6III: *Syllabus III, 1978* – Wilmington, (DE), hours 1–6 (other examples given in hours 7–11).
 B-2: *From Atomistic Thinking to Cybernetic Comprehensive Consciousness*, Class, 1970
 Ogunquit, (ME), hour 2.
 D-4: *Divine Cybernetics and the Self-operating “Dimensional Laws” of the One Being, God*,
 Series of talks 1971/72 – New York, hours 7–8.

Books by John Doorly:

Talks on the Science of the Bible, Vol. I, “red-book,” pp. 57–61.

Word-order
the law of creativity

divinely			—————→	humanly		annihilates
subjective I Am (S&H 465)	I Am not:	objective		objective (3 rd degree)	subjective (our attitude to God)	wrong concept about God
MIND	mortal mind	intelligence	Christ- impact →	wisdom	seeking God	ignorance agnosticism
SPIRIT	matter	substance the Only	→	purity	choosing the spiritual	dualism polytheism
SOUL	sense-testimony (body)	identity, Ego	→	spiritual understanding	self-abnegation	sin pantheism
PRINCIPLE	person	the One	→	spiritual power	obedience	anthropomorphic sense of God
LIFE	death, mortality	individuality eternality	→	love	laying down the mortal	pride of life vitalism
TRUTH	error	consciousness	→	health	affirmation of Truth	denying Truth theodicy
LOVE	nothingness	perfection	→	holiness	unity with God	nihilism

References to the previous diagram, *Word-order the law of creativity*:

Books by Max Kappeler:

The Four Levels of Spiritual Consciousness: Science itself, divine Science, absolute Christian Science, Christian Science, pp.181–187.

The Seven Synonyms for God, Chapter 6: The Word-order.

Recordings by Max Kappeler

A-4: *The Structure-principle of Being: Our need for a divine system of reference*, Class, 1974, Wilmington, (DE).

B-2: *From Atomistic Thinking to Cybernetic Comprehensive Consciousness*, Class, 1970, Ogunquit, (ME).

D-4: *Divine Cybernetics and the Self-operating “Dimensional Laws” of the One Being, God*, Series of talks 1971/72 – New York, hours 8–9.

E-1: *The Structure of Being and its Universal Laws*, Class, 1973 – New York, hours 15–17A.

Books by John W. Doorly

Talks at the Oxford Summer School, 1948, Vol. I, pp. 21–22.

Talks on the Science of the Bible, #67 “blue-book,” pp. 4–15.

Talks on the Science of the Bible, #69 “blue-book,” pp. 5–10.

Talks on the Science of the Bible, Vol. I “red-book,” pp. 218–219.

Talks on the Science of the Bible, Vol. VII “red-book,” pp. 281–282, 343–348.

The Christ-translation (S&H 115:12–116:5)

Scientific translation of immortal Mind

Divine synonyms	GOD:	Divine Principle, Life, Truth, Love, Soul, Spirit, Mind.
Divine image	MAN:	God’s spiritual idea, individual, perfect, eternal.
Divine reflection	IDEA:	An image in Mind: the immediate object of understanding. (Webster)

Scientific translation of mortal mind

First Degree: Depravity

Unreality	<i>Physical.</i> Evil beliefs, passions and appetites, fear, depraved will, self-justification, pride, envy, deceit, hatred, revenge, sin, sickness, disease, death.
-----------	--

Second Degree: Evil beliefs disappearing

Transitional qualities	<i>Moral.</i> Humanity, honesty, affection, compassion, hope, faith, meekness, temperance.
------------------------	--

Third Degree: Understanding

Reality	<i>Spiritual.</i> Wisdom, purity, spiritual understanding, spiritual power, love, health, holiness. “In the third degree mortal mind disappears, and man as God’s image appears.”
---------	--

References to the diagram, “The Christ-translation (S&H 115:12–116:5)”:

Books by Max Kappeler:

- Complete Compendium for the Study of Christian Science*, # 1: Introduction, p. 1.
Epitomes for the Spiritually Structured Interpretation of the Christian Science Textbook, p. 2.
Introduction to the Science of Christian Science, pp.39–47.
The Minor Prophets in the Light of Christian Science, pp. 13–16, 22–25.
The Seven Synonyms for God, Chapter 6.

Books by John Doorly:

- Talks at the Oxford Summer School, 1948*, Vol. I, pp. 112–115, 164–166.
Talks at the Oxford Summer School, 1948, Vol. II, pp. 138–141.
Talks on the Science of the Bible, Vol. I, “red-book,” pp. 71–73.
Talks on the Science of the Bible, Vol. II, “red-book,” pp. 27–28, 33–35, 302–304.
Talks on the Science of the Bible, Vol. III, “red-book,” pp. 64–65, 292–293, (vs. absolutism or no translatability to the flesh), 272–375.
Talks on the Science of the Bible, Vol. IV, “red-book,” pp. 134–135, 150–151, 183–184, 218–219, 238–241, 250–254, 265–270.
Talks on the Science of the Bible, Vol. IX, “red-book,” pp. 230–231.
Talks on the Science of the Bible, #65 “blue-book,” p. 4–5, 14–15, 21–23.
Talks on the Science of the Bible, #66 “blue-book,” pp. 4–5.
Talks on the Science of the Bible, #70 “blue-book,” pp. 22–23.
Talks on the Science of the Bible, #72 “blue-book,” pp. 5–10.

Recordings by Max Kappeler:

- A-1: *An Introduction to the Science of Christian Science*, Class, 1962, Zürich, Switzerland, hours 10A–12.
A-4: *The Structure-principle of Being: Our need for a divine system of reference*, Class 1974 – Wilmington, (DE), hours 17B–19A.
A-6IV: *Syllabus IV*, 1979 – Wilmington, (DE)/Elizabethtown, (PA), hours 4–5, 9–10.
C-1S: *CH. VI, Science, Theology, Medicine, The Structure of the Christian Science Textbook—Our Way of Life*, Series of Talks: 1978, hours 14–15 (hours 6–7, if numbered from the beginning of the chapter).
D-4: *Divine Cybernetics and the Self-operating “Dimensional Laws” of the One Being, God*, Series of talks 1971/72 – New York, hours 15–16.

The Christ order

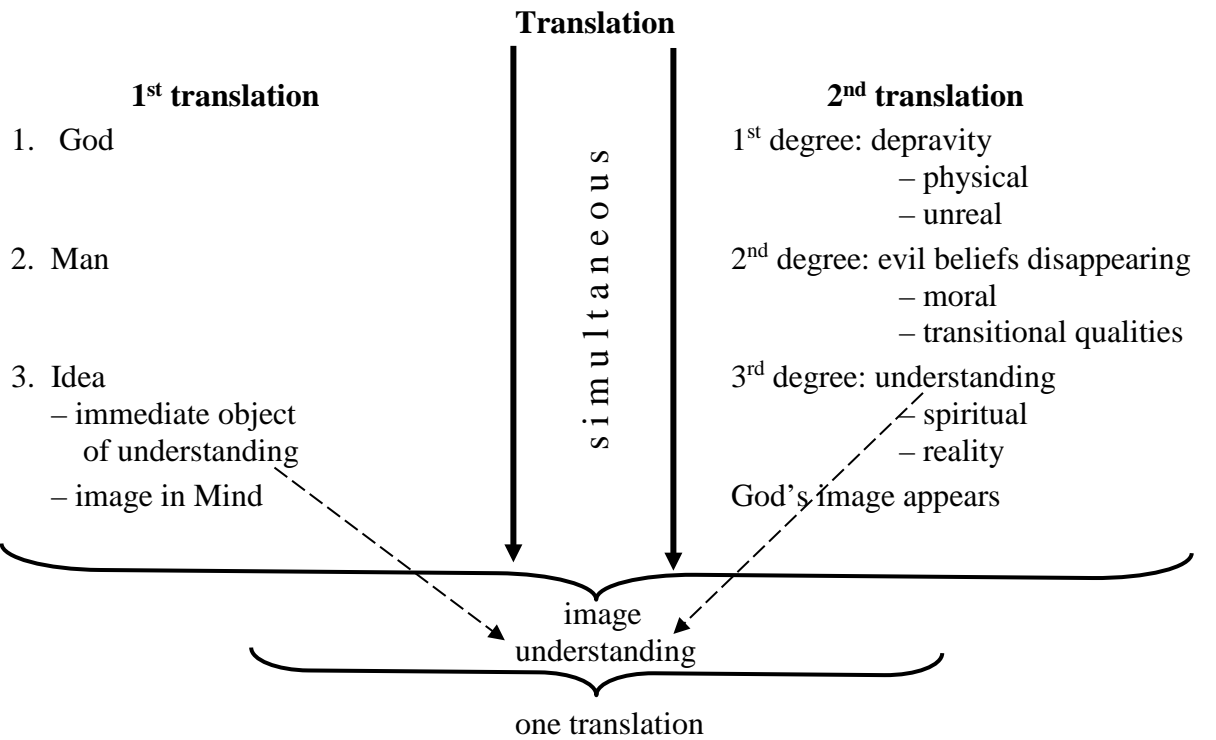
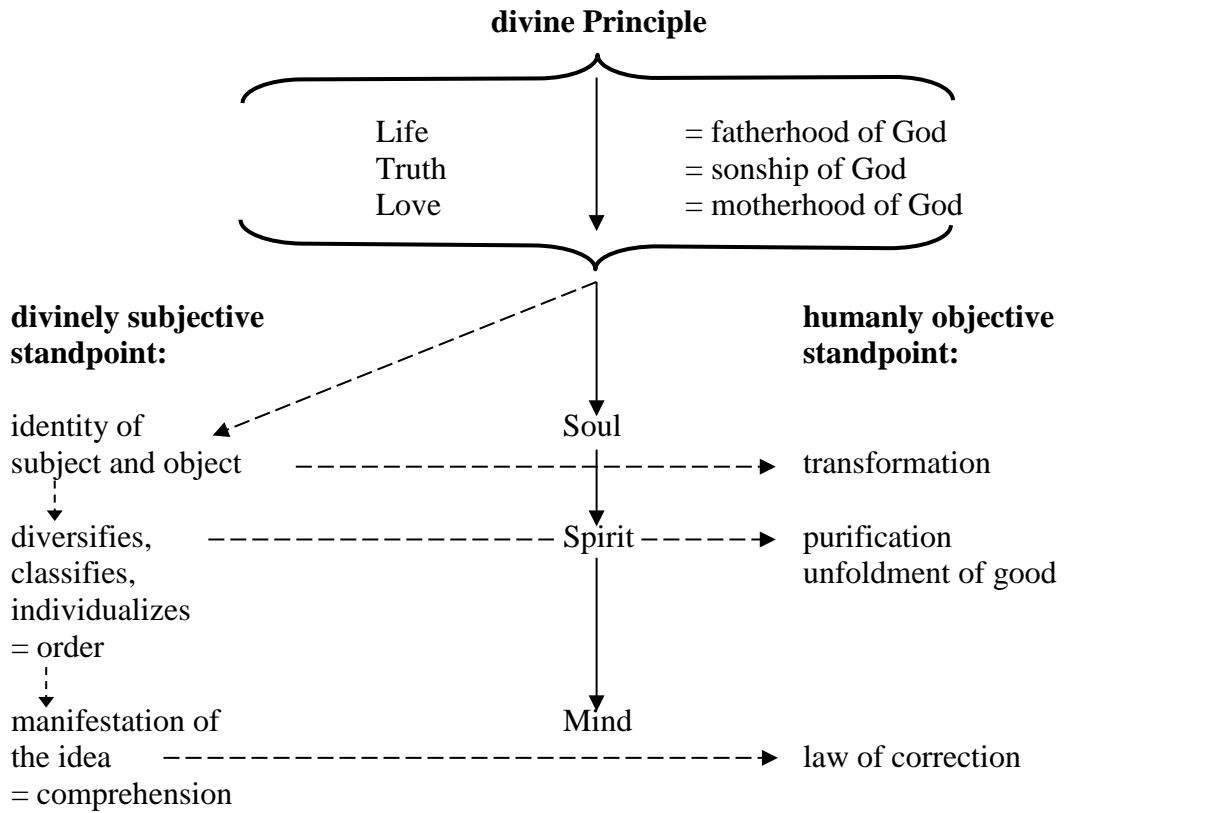

References to the previous diagram, “The Christ-order”:

Books by Max Kappeler:

- Complete Compendium for the Study of Christian Science*, p. 22.
Epitomes for the Spiritually Structured Interpretation of the Christian Science Textbook, p. 2.
Introduction to the Science of Christian Science, pp.39–47.
The Minor Prophets in the Light of Christian Science, pp. 13–16, 22–25.
The Seven Synonyms for God, Chapter 6.

Recordings by Max Kappeler:

- A-1: *An Introduction to the Science of Christian Science*, Class, 1962, Zürich, Switzerland, hours 10A–12.
A-4: *The Structure-principle of Being: Our need for a divine system of reference*, Class, 1974, Wilmington, (DE), hours 17B–19A.
A-6IV: *Syllabus IV*, 1979, Wilmington, (DE) hours 4–5, 9–10.
C-1S: *CH. VI, Science, Theology, Medicine, The Structure of the Christian Science Textbook—Our Way of Life*, Series of Talks: 1978, hours 14–15 (hours 6–7, if numbered from the beginning of the chapter).
D-4: *Divine Cybernetics and the Self-operating “Dimensional Laws” of the One Being, God*, Series of talks 1971/72 – New York, hours 15–16.

Books by John Doorly:

- Talks at the Oxford Summer School, 1948*, Vol. I, pp. 112–115, 164–166.
Talks at the Oxford Summer School, 1948, Vol. II, pp. 138–141.
Talks on the Science of the Bible, Vol. I, “red-book,” pp. 71–73.
Talks on the Science of the Bible, Vol. II, “red-book,” pp. 27–28, 33–35, 302–304.
Talks on the Science of the Bible, Vol. III, “red-book,” pp. 64–65, 292–293, (vs. absolutism or no translatability to the flesh), 272–375.
Talks on the Science of the Bible, Vol. IV, “red-book,” pp. 134–135, 150–151, 183–184, 218–219, 238–241, 250–254, 265–270.
Talks on the Science of the Bible, Vol. IX, “red-book,” pp. 230–231.
Talks on the Science of the Bible, #65 “blue-book,” p. 4–5, 14–15, 21–23.
Talks on the Science of the Bible, #66 “blue-book,” pp. 4–5.
Talks on the Science of the Bible, #70 “blue-book,” pp. 22–23.
Talks on the Science of the Bible, #72 “blue-book,” pp. 5–10.

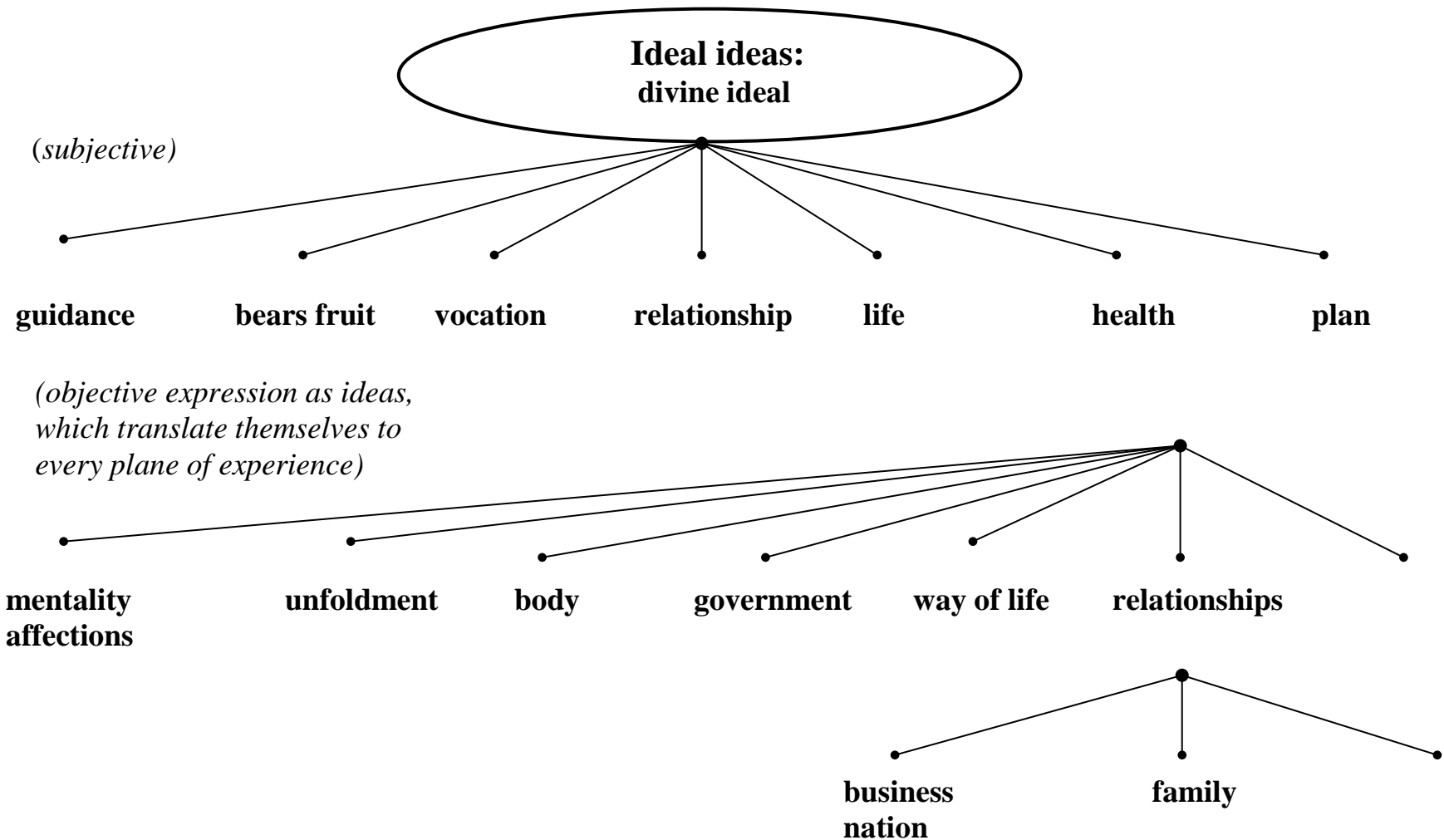

References:

Books by Max Kappeler:

Introduction to the Science of Christian Science, pp. 102–106.

Recordings by Max Kappeler:

- A-4: *The Structure-principle of Being: Our need for a divine system of reference*, Class 1974 – Wilmington, (DE), hours 6–9.
- D-2 *Divine Cybernetics: The proto-science, the integral Science*, Class, 1969 – Braunwald, Switzerland, hour 12.
- D-4: *Divine Cybernetics and the Self-operating “Dimensional Laws” of the One Being, God*, Series of talks 1971/72 – New York, hour 14.

Books by John W. Doorly:

- Christian Science Practice*, pp. 310–311.
- Talks at the Oxford Summer School, 1948*, Vol. I, pp. 95–97 (ideas are power).
- Talks at the Oxford Summer School, 1949*, Vol. II, pp. 140–145 (the nature and operation of ideas), p. 169.
- Talks on the Science of the Bible*, #70 “blue-book,” pp. 24–25.
- Talks on the Science of the Bible*, Vol. I “red-book,” pp. 125–126.
- Talks on the Science of the Bible*, Vol. II “red-book,” pp. 212–213.
- Talks on the Science of the Bible*, Vol. VI “red-book,” pp. 65–66.

Christ-order
the law of translation and reformation

synonyms (S&H: 115)	divine standpoint		human standpoint	
	divinely subjective/objective		when we let it happen	When we resist it
(subjective)				
Principle	potential power		divine authority	imperative – apodictical
Life	dynamic power		spontaneous power – generating power	irrepressible power – irresistible power
Truth	conscious power		penetrating power – dominating power	crushing power
Love	power of total engagement		power of salvation	enforcing power
(objective)				
Soul	identifying power – translating power		transforming power – reverses – exchanges	suffering
Spirit	ordering power – ordering hierarchically		purifying power – excludes – separates	chemicalization – crises – conflict – frustration
Mind	manifesting power		enlightening power – corrects – leads – heals	animal magnetism – ignorance

References:

Books by Max Kappeler:

- The Christ-idea*, ©1969, 2nd edition 2002.
- The Four Levels of Spiritual Consciousness: Science itself, divine Science, absolute Christian Science, Christian Science*, pp.187–192.
- Introduction to the Science of Christian Science*, pp.39–55, 115–124.
- The Minor Prophets in the Light of Christian Science*, pp. 197–198.
- The Seven Synonyms for God*, Chapter 6: The Christ-order.

Recordings by Max Kappeler:

- A-6IV: *Syllabus IV*, 1979 – Wilmington, (DE), hours 5–8 (hours 11–17: Christ-order illustrated in “Romans”).
- D-4: *Divine Cybernetics and the Self-operating “Dimensional Laws” of the One Being, God*, Series of talks 1971/72 – New York, hours 13–16.
- E-1: *The Structure of Being and its Universal Laws*, Class, 1973 – New York, hours 17–19.

Books by John W. Doorly:

- Christian Science Practice*, pp. 34–35, 174.
- Talks at the Oxford Summer School, 1948*, Vol. I, pp. 95–97 (ideas are power).
- Talks on the Science of the Bible*, #67 “blue-book,” pp. 19–25.
- Talks on the Science of the Bible*, #69 “blue-book,” pp. 10–16.
- Talks on the Science of the Bible*, Vol. I “red-book,” pp. 219–220.
- Talks on the Science of the Bible*, Vol. III “red-book,” pp. 367–368, 370.
- Talks on the Science of the Bible*, Vol. VI “red-book,” pp. 250–254.
- Talks on the Science of the Bible*, Vol. IX “red-book,” pp. 66–67 (from W-order to X-order).

The development of the Christianity-order

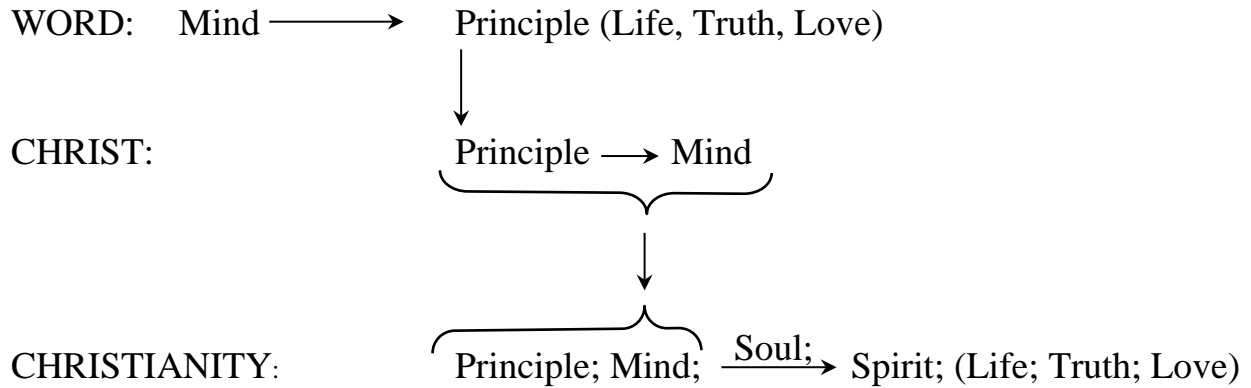

The derivation of the Christianity-order from absolute Christian Science

	<i>Christianity</i>	
divine Science	<div style="border: 1px solid black; border-radius: 50%; width: 100px; height: 30px; margin: 0 auto; display: flex; align-items: center; justify-content: center;"> one Love </div>	
absolute Christian Science	Life ↓	Love ↓
Christian Science	<i>S&H</i> 468:26	Principle, Mind, Soul, Spirit ───────────────────┐
	592:16	Principle Life, Truth, Love ───────────────────┐
	587:6	───────────────────┐ Principle; Mind; Soul; Spirit; Life; Truth, Love ───────────────────┘

References to the diagram, “The development of the Christianity-order”

Recordings by Max Kappeler:

D-4: *Divine Cybernetics and the Self-operating “Dimensional Laws” of the One Being, God*, Series of talks 1971/72 – New York, hour 19.

Books by John W. Doorly:

Talks at the Oxford Summer School, 1948, Vol. II, pp. 23.

Talks at the Oxford Summer School, 1949, Vol. II, pp. 33–34.

Talks on the Science of the Bible, #66 “blue-book,” pp. 28–29, 29–31.

Talks on the Science of the Bible, #68 “blue-book,” pp. 5–7.

Talks on the Science of the Bible, Vol. IX “red-book,” p. 96.

References to “The derivation of the Christianity-order from absolute Christian Science”

Recordings by Max Kappeler:

D-4: *Divine Cybernetics and the Self-operating “Dimensional Laws” of the One Being, God*, Series of talks 1971/72 – New York, hour 19.

Books by John W. Doorly:

Christian Science Practice, pp. 245–246.

Talks at the Oxford Summer School, 1949, Vol. II, pp. 16–17.

The inverted Christianity-order

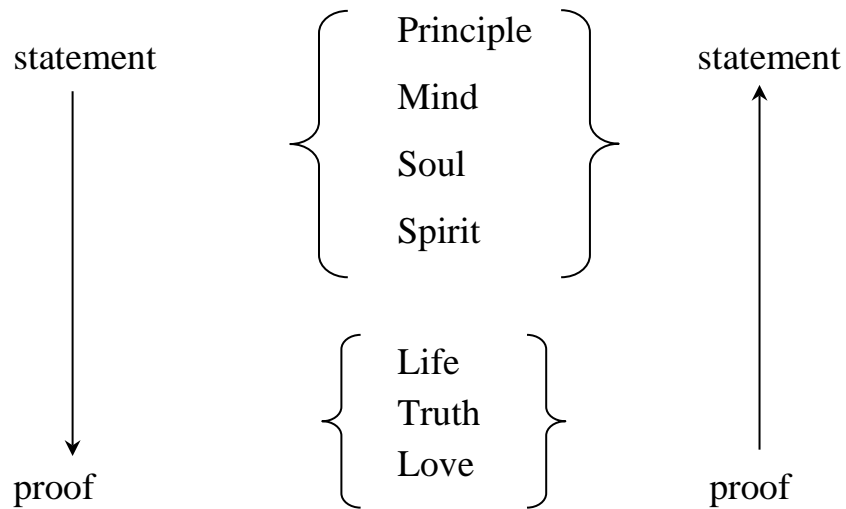

References:

Recordings by Max Kappeler:

D-4: *Divine Cybernetics and the Self-operating "Dimensional Laws" of the One Being, God*, Series of talks 1971/72 – New York, hour 20B.

Books by John W. Doorly:

Talks at the Oxford Summer School, 1948, Vol. II, pp. 11–13.
Talks at the Oxford Summer School, 1949, Vol. II, (Luke is laid out in the inverted order pp. 9–10, 12–14, 46, 218.

Christianity-order
the law of reflection and demonstration

<i>synonyms</i> (S&H 587)	<i>nature of ideas</i>	<i>true humanhood</i>	<i>mortal man</i>
Principle	all ideas have only one Principle	principled – impersonal	personal “I”
Mind	all is idea (the realm of ideas)	thinking in ideas	thinking in false beliefs – illusions – misconceptions – opinions
Soul	every idea is identified with Principle	unselfed – selfless	egotistic
Spirit	every idea reflects every other idea	spiritually minded – spiritual transparency	materialistic
Life	fatherhood of the idea	fullness of true manhood	destructive – sense of lack
Truth	sonship of the idea	man having dominion – brotherhood	negative
Love	motherhood of the idea	fulfilled manhood	nihilistic – fatalistic

References:

Books by Max Kappeler:

The Four Levels of Spiritual Consciousness: Science itself, divine Science, absolute Christian Science, Christian Science, pp.192–195.

The Seven Synonyms for God, Chapter 6: The Christianity-order.

Recordings by Max Kappeler:

A-4: *The Structure-principle of Being: Our need for a divine system of reference*, Class 1974 – Wilmington, (DE), hour 19A.

A-6IV: *Syllabus IV*, 1979 – Wilmington, (DE), hours 18–22.

D-4: *Divine Cybernetics and the Self-operating “Dimensional Laws” of the One Being, God*, Series of talks 1971/72 – New York, hours 17–21.

E-1: *The Structure of Being and its Universal Laws*, Class, 1973 – New York, hours 19–22.

Books by John W. Doorly:

Talks at the Oxford Summer School, 1948, Vol. I, pp. 23–24.

Talks at the Oxford Summer School, 1949, Vol. II, pp. 78–79.

Talks on the Science of the Bible, #67 “blue-book,” pp. 4–15.

Talks on the Science of the Bible, #69 “blue-book,” pp. 17, 31–32.

Talks on the Science of the Bible, #70 “blue-book,” pp. 11–15.

Talks on the Science of the Bible, #71 “blue-book,” p. 10.

Talks on the Science of the Bible, Vol. I “red-book,” p. 245.

Talks on the Science of the Bible, Vol. III “red-book,” pp. 375.

The Triune Person

<i>Word</i>	<i>Christ</i>	<i>Christianity</i>
Father	fatherhood of God	fatherhood of the idea
Son	sonship of God	sonship of the idea
Mother	motherhood of God	motherhood of the idea
		<ul style="list-style-type: none">1. to ourselves2. to others3. others to themselves4. others to us
		one universal reflection

References:

Recordings by Max Kappeler:

D-4: *Divine Cybernetics and the Self-operating "Dimensional Laws" of the One Being, God*, Series of talks 1971/72 – New York, hour 20.

Books by John W. Doorly:

Christian Science Practice, pp. 61–62 (Father, Son, Mother).

The Family-Law
universal reflection of ideas

fatherhood
sonship
motherhood

} of ideas

fatherhood of ideas (Life)

provides, maintains, gives, supports, projects, feeds...

- a) to itself
- b) to every other idea (= universe)
- c) every other idea to itself
- d) every other idea to every other idea

sonship of ideas (Truth)

affirms, claims, confirms, takes possession...

- a) to itself
- b) to every other idea (= universe)
- c) every other idea to itself
- d) every other idea to every other idea

motherhood of ideas (Love)

protects, cherishes, preserves, embraces...

- a) to itself
- b) to every other idea (= universe)
- c) every other idea to itself
- d) every other idea to every other idea

References:

Books by Max Kappeler:

The Four Levels of Spiritual Consciousness: Science itself, divine Science, absolute Christian Science, Christian Science, p. 194.

The Seven Synonyms for God, chapter 6: the Christianity-order.

Recordings by Max Kappeler:

A-6IV: *Syllabus IV*, 1979 – Wilmington, (DE), hour 20–22A

D-4: *Divine Cybernetics and the Self-operating "Dimensional Laws" of the One Being, God*, Series of talks 1971/72 – New York, hour 20B.

E-1: *The Structure of Being and its Universal Laws*, Max Kappeler, Class, 1973 – New York, hour 20.

Books by John W. Doorly:

Talks at the Oxford Summer School, 1949, Vol. II, pp. 82–83 (right relationship in Christianity).

Science-order

Word-order (S&H 465): ordered sequence

Mind → Spirit → Soul → Principle → Life → Truth → Love

Science-order: order becomes structure (candlestick)

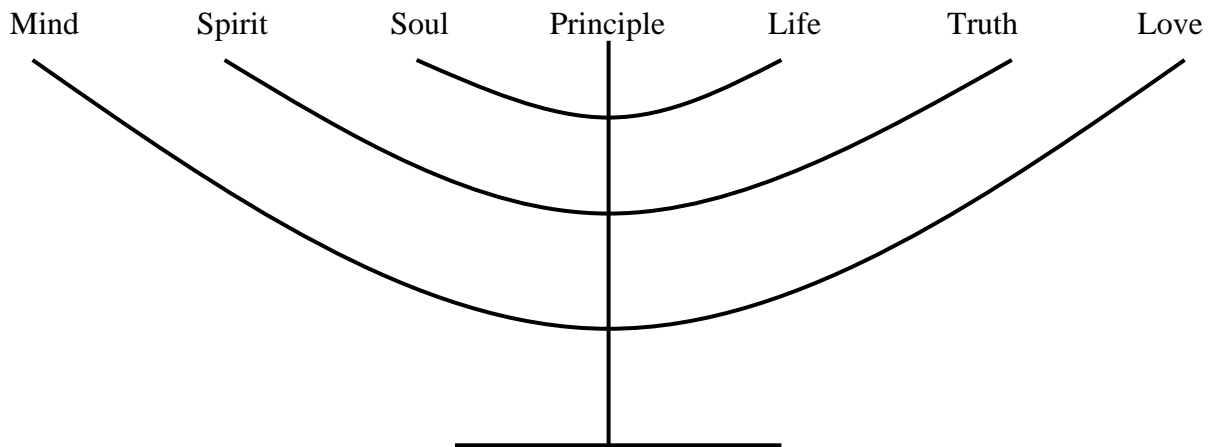

Science-order reveals structure

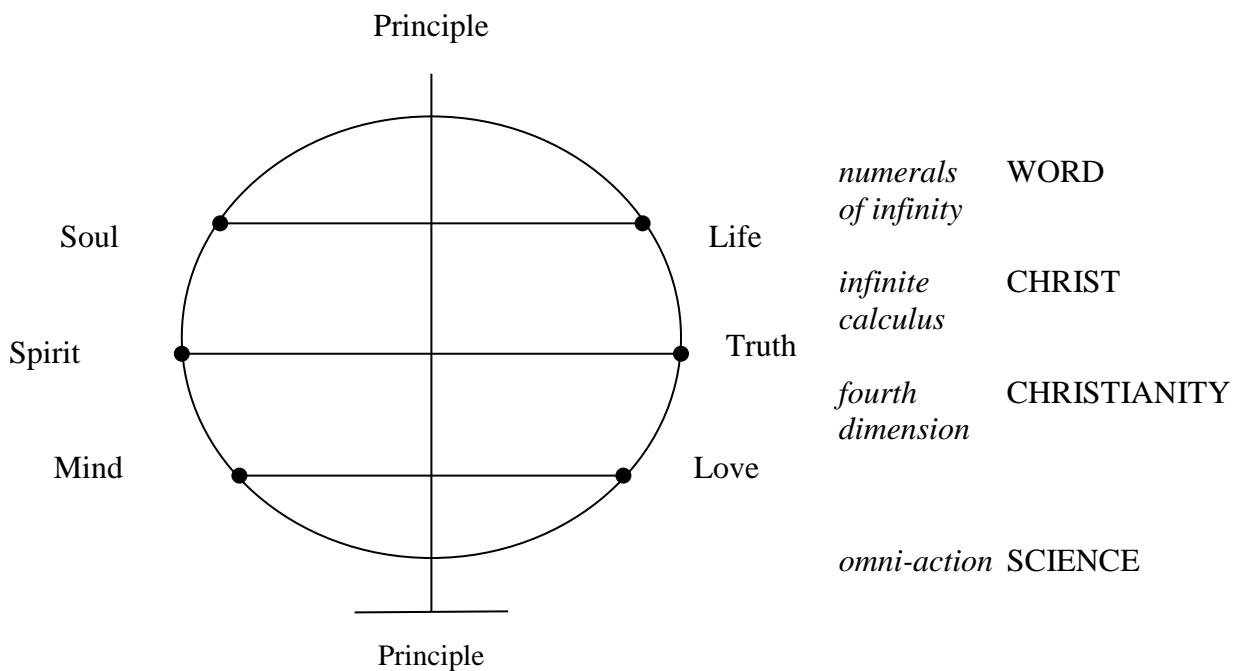

References to Science-order:

Word-order (S&H 465): ordered sequence

Recordings by Max Kappeler:

A-4: *The Structure-principle of Being: Our need for a divine system of reference*, Class 1974 – Wilmington, (DE), hour 19B.

D-4: *Divine Cybernetics and the Self-operating “Dimensional Laws” of the One Being, God*, Series of talks 1971/72 – New York, hours 23–24.

Books by John W. Doorly:

Christian Science Practice, pp. 61–62 (Father, Son, Mother).

Talks at the Oxford Summer School, 1948, Vol. II, p. 130.

Talks at the Oxford Summer School, 1949, Vol. II, p. 269.

Science-order reveals structure

Books by Max Kappeler:

The Four Levels of Spiritual Consciousness: Science itself, divine Science, absolute Christian Science, Christian Science, pp. 195-198.

The Seven Synonyms for God, chapter 6: the Science-order.

Recordings by Max Kappeler:

D-4: *Divine Cybernetics and the Self-operating “Dimensional Laws” of the One Being, God*, Series of talks 1971/72 – New York, hours 23–24.

Science-order
the law of structured understanding

<i>synonyms</i>	<i>the structure of scientific being</i>	<i>divinely scientific understanding</i>	<i>human understanding of Science</i>	<i>unscientific understanding (misunderstanding)</i>
Soul + Life (1) <i>numerals of infinity</i> Word	unchanging identities of being (ideas of the seven synonyms for God)	being can be identified only through spiritual understanding (spiritual sense)	as we understand spiritually, so are we	mortal beliefs produce mortal existence
Spirit + Truth (2) <i>infinite calculus (divine computations)</i> Christ	every idea reflects being in a different, specific and new form	Truth is a fact-ordering activity (seeing order in chaos)	through the restructuring of facts, we make new discoveries	calculating humanly leads to false conclusions (combinatorics)
Mind + Love (3) <i>4th dimension (matrix)</i> Christianity	each idea has its own perfection (its right place within the whole)	perfection operates according to law (miracle) (the impossible happens)	through taking a holistic view, we find better and higher answers, which bring both an individual and collective blessing	atomistic thinking is structure-blind, and blind to the future
Principle (4) <i>omni-action</i> Science	all that is going on is the omni-action of Principle	Principle operates through Science and system as the all-harmony of being	we furnish true, holistic proof	enigmatical, unscientific thinking, mysticism

References:

Books by Max Kappeler

The Four Levels of Spiritual Consciousness: Science itself, divine Science, absolute Christian Science, Christian Science, pp.195–198.
The Seven Synonyms for God, Chapter 6: The Science-order.

Recordings by Max Kappeler

A-6IV: *Syllabus IV*, 1979, Wilmington, (DE), hours 23–25.
D-4: *Divine Cybernetics and the Self-operating “Dimensional Laws” of the One Being, God*, Series of talks 1971/72 – New York, hours 22–24.
E-1: *The Structure of Being and its Universal Laws*, Class, 1973 – New York, hours 22–23.

Books by John W. Doorly

Talks at the Oxford Summer School, 1948, Vol. I, p. 24.
Talks at the Oxford Summer School, 1949, Vol. II, pp. 235–236, 241–242, 253–255.

Category III

THE 4 LEVELS OF SCIENCE:

Science itself
divine Science
absolute Christian Science
Christian Science

The dimensional aspect of Being is the four levels of Science itself, divine Science, absolute Christian Science, and Christian Science. This development of defining the seven synonymous terms for God and the four sides of the holy city as Word, Christ, Christianity, and Science has brought us up to the time of World War II. Though it seemed that much had been achieved, there was still something missing. Quite a few paradoxical questions remained unsolved, and a fundamental key was needed to solve them. They were the paradoxes that every sincere thinker encounters when studying the Textbook. To take two simple examples:

- Christian Science teaches on the one hand that God knows no sickness and on the other hand that God heals sickness;
- that there is no evil and yet that we have to overcome evil.

For those thinking along the lines of classical logic, such seeming paradoxes or contradictions are encountered again and again in the Textbook. But in fact Mrs. Eddy does not contradict herself, if the Textbook is read with the transclassical logic which she was already using a century before the other sciences and the world awoke to it. As she wrote the Textbook in a structural way and not according to one-dimensional linear reasoning, her teaching can only be understood through a multi-dimensional logic.

John Doorly realized that the subject of the Textbook has various levels of spiritual altitudes and that this is brought out by the various levels of Science. He showed that any subject has a different aspect according to whether it is treated from the point of view of *Science itself*, from *divine Science*, from *absolute Christian Science* or from *Christian Science*. Therefore the student must approach the Christian Science textbook with a consciousness that is cultured in thinking dimensionally with a dimensional logic, and then the seeming paradoxes can be solved even rationally.²

² See Max Kappeler, *The Four Levels of Spiritual Consciousness: Science itself, divine Science, absolute Christian Science, Christian Science*.

From Metaphysics to Science

The ordered steps to finding our oneness with Being (Resolving the “personal I” into the “I Am”)

ascending way

Metaphysics: the contemplation of ideas

1. All is mental (*cogito, ergo sum*)
2. The mental can be good or evil
3. Thinking in terms of ideas
4. Thinking in terms of the synonyms for God

Science: the contemplation of the infinite One, including all ideas

5. Only the synonyms for God in us can be one with synonym of God
6. Life, Truth, and Love is the only “I” of us
7. The synonyms of God are the only “I” or Ego
8. The “I” is “I AM”

descending way

Science:

8. I Am that I Am
7. This I Am is the “I am” of all
6. This I Am is infinitely individualized as “individual I am”
5. This I AM has no other “I Am,” no “personal I”

Science including metaphysics:

4. This I AM is “the thinker” of us
3. This I AM gives us ideas/makes God’s thoughts and “my” thoughts identical
2. This I AM gives only good thoughts
1. This I AM makes us “the thought of” God and therefore, “I am” (*cogitor, ergo sum*)

References for “From Metaphysics to Science: The ordered steps to finding man’s oneness with Being”:

Books by Max Kappeler:

The Four Levels of Spiritual Consciousness: Science itself, divine Science, absolute Christian Science, Christian Science, pp. 7–9, 55–59.

From metaphysics to Science:

Books by Max Kappeler:

Animal Magnetism – Unmasked, pp. 184–192.

Books by John Doorly:

Talks at the Oxford Summer School, 1948, Vol. II, pp. 118–120.

Talks at the Oxford Summer School, 1949, Vol. II, pp. 131–132.

Recordings by Max Kappeler:

B-2: *From Atomistic Thinking to Cybernetic Comprehensive Consciousness*, Class, 1970 – Ogunquit, (ME), hour 23.

D-2: *Divine Cybernetics: The proto-science, the integral Science*, Class, 1969, Braunwald, Switzerland, hours 6–7.

X-13: *The Eight Ordered Steps to Finding our Oneness with Being*, one hour from B2 (#23).

Recordings by Max Kappeler:

A-4: *The Structure-principle of Being: Our need for a divine system of reference*, Class 1974 – Wilmington, (DE), hour 23.

A-5: *A Seminar on the 7 Synonymous Terms for God*, Seminar 1975, Wilmington, (DE), hours 19B-21 (also listed separately as X-8): the 7 synonyms from the two standpoints.

C-1S: *CH. VI, Science, Theology, Medicine, The Structure of the Christian Science Textbook—Our Way of Life*, Series of Talks: 1978, hours 10–11, 37 (2–3, 29, if numbered from the beginning of the chapter).

D-1: *The 4 Levels of Science*, Series of Talks 1967/68 – London, England, hours 1, 6A.

X-8: *Metaphysics Contrasted with Science*, 2 hours from A-5 (#19B, 20, 21).

ascending way of understanding and descending way of demonstration:

Books by Max Kappeler:

The Four Levels of Spiritual Consciousness: Science itself, divine Science, absolute Christian Science, Christian Science, pp. 74–77.

Books by John Doorly:

Talks at the Oxford Summer School, 1949, Vol. I, pp. 21–24.

Talks on the Science of the Bible, #59 “blue-book,” pp. 13–16.

Talks on the Science of the Bible, #61 “blue-book,” pp. 3–10, 31–32 (progressive from objective to the subjective viewpoint).

Recordings by Max Kappeler:

D-1: *The 4 Levels of Science*, Series of Talks 1967/68 – London, England, hours 8B, 17–20.

ascending and descending in ‘The Apocalypse’:

Books by Max Kappeler:

The Structure of the Christian Science Textbook, Vol. I, pp. 177–185.

The Science of the Oneness of Being in the Christian Science Textbook, pp. 239–248.

Epitomes for the Spiritually Structured Interpretation of the Christian Science, “The Apocalypse”, pp. 3–4.

Books by John Doorly:

Talks on the Science of the Bible, #58 “blue-book,” pp. 9–16

Dimensionalism (against reductionism)

Diagram A

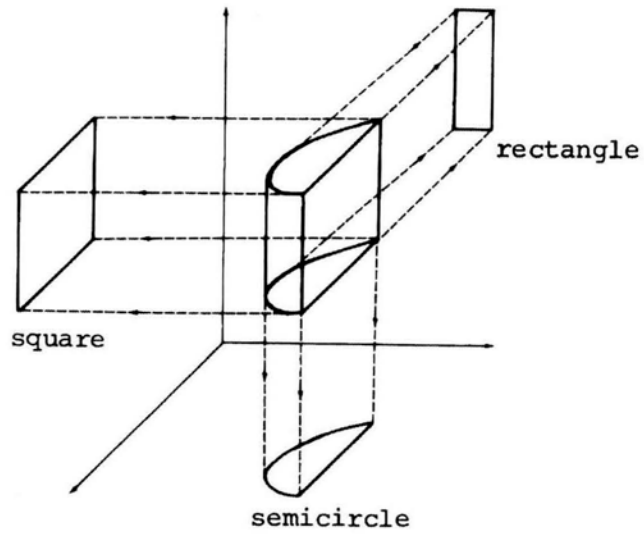

Diagram B

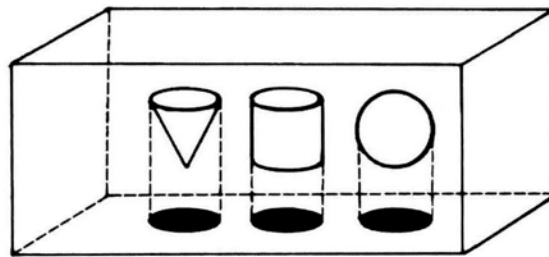
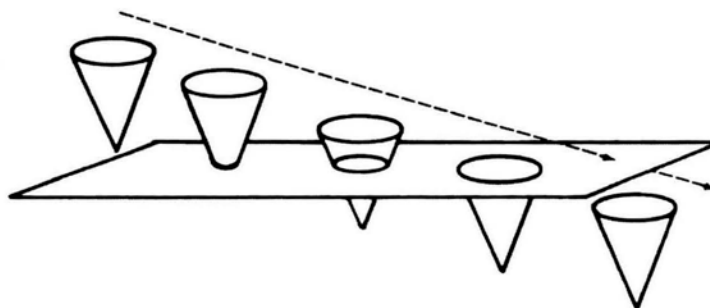

Diagram C



References to the previous diagram, “Dimensionalism (against reductionism)”:

Recordings by Max Kappeler:

- A-4: *The Structure-principle of Being: Our need for a divine system of reference*, Class 1974 – Wilmington, (DE), hour 20.
- A-6V: *Syllabus V*, 1980, hour 3.
- B-2: *From Atomistic Thinking to Cybernetic Comprehensive Consciousness*, Class, 1970 – Ogunquit, (ME), hour 17.
- D-4: *Divine Cybernetics and the Self-operating “Dimensional Laws” of the One Being, God*, Series of talks 1971/72 – New York, hour 3.
- G-2: *The Science of Being—As I See It Today*, Lecture, 1970 – London, England, hours 6–7.

Books by Max Kappeler:

The Seven Synonyms for God, Chapter 7.

The Science of the Oneness of Being in the Christian Science Textbook, pp. 49–51.

The Four Levels of Spiritually Scientific Consciousness

Science itself	Principle itself	infinite One	the only	indivisible	the whole	integral	I Am	self-operation
divine Science	Principle and idea is one	oneness	All-in-all	inseparable	co-existence	closed system	triune Person: Li, T, Lo (divine ideal)	Principle and spiritual power is one
absolute Christian Science	relationship between Principle and idea	unity	the calculation of specific truths	inter-relationships	calculus of ideas	open system	ideal ideas	demonstration of spiritual values
Christian Science	ideas dissolve illusions	makes one	resolves duality	isolation dissolved; reconciliation	dissolves atomistic thinking	resolves system of false beliefs	unselfed "I"	self-regulating: error elimination

References:

Books by Max Kappeler:

The Four Levels of Spiritual Consciousness: Science itself, divine Science, absolute Christian Science, Christian Science, pp. 63–77.

Books by John Dooley:

The Pure Science of Christian Science, pp. 24–29.

Talks on the Science of the Bible, #70 "blue-book," pp. 3–4.

Recordings by Max Kappeler:

A-4 *The Structure-principle of Being: Our need for a divine system of reference*, Class 1974 – Wilmington, (DE), hours 20–22.

A-6V: *Syllabus V*, 1980, hours 3–6A.

B-2 *From Atomistic Thinking to Cybernetic Comprehensive Consciousness*, Class, 1970 – Ogunquit, (ME), hours 18–19A.

D-1: *The 4 Levels of Science*, Series of Talks 1967/68 – London, England, hours 6–8, 10.

D-2: *Divine Cybernetics: The proto-science, the integral Science*, Class, 1969 – Braunwald, Switzerland, hour 3.

D-4 *Divine Cybernetics and the Self-operating "Dimensional Laws" of the One Being, God*, Series of talks 1971/72 – New York, hours 3–4.

The Four Levels of Spiritually Scientific Consciousness How the levels provide a dimensional analysis of specific issues

	<i>life</i>	<i>death</i>	<i>evil</i>	<i>matter</i>	<i>healing</i>	<i>problems</i>	<i>demonstration</i>	<i>c. of levels</i>
<i>Science itself</i>	I Am Life	unknown	unknown	unknown	whole	unknown	of itself	fatalism
<i>divine Science</i>	Life lives Life: eternal Life	no possibility of death: there is no death	excluded	excluded	instantaneous healing: wholeness	excluded	divine origin	mysticism
<i>absolute Christian Science</i>	Life lives Life: newness of life	Life, Truth, Love, make man undying	God, good, misunderstood	Spirit not seen as such	preventive practice: handles source of error (prophylactic)	solves positive problems	newness, progression, unfoldment of spiritual values	absolutism
<i>Christian Science</i>	Life lives me: we live the one Life in spite of the body	Life spiritually discerned overcomes the belief in death	good over evil: misunderstanding resolved	Spirit over matter: destroys belief in matter	curative practice: handles the effect of error (therapeutic)	solves negative problems	victory over sin, sickness, disease and death	pragmatism: trying to use the spiritual to improve matter

References:

Books by Max Kappeler:

The Development of the Christian Science Idea and Practice ©2004, 2nd edition, pp. 62–66
(healing on the levels), statement pp. 25–27.

The Four Levels of Spiritual Consciousness: Science itself, divine Science, absolute Christian Science, Christian Science, pp. 77–87.

Recordings by Max Kappeler:

A-6V: *Syllabus V*, 1980, hours 6–10.

D-1: *The 4 Levels of Science*, Series of Talks 1967/68 – London, England, hour 24.

D-2: *Divine Cybernetics: The proto-science, the integral Science*, Class, 1969 – Braunwald, Switzerland, hours 4–6.

D-4: *Divine Cybernetics and the Self-operating “Dimensional Laws” of the One Being, God*, Series of talks 1971/72 – New York, hours 4–5.

The Four Levels of Science Reflected in Genesis 1:1
(S&H 502:21–503:5)

“In the beginning God created the heaven and the earth.”

Science itself

“The infinite has no beginning. This word *beginning* is employed to signify the *only*...

divine Science

“...that is, the eternal verity and unity of God and man, including the universe.”

absolute Christian Science

“The creative Principle — Life, Truth, and Love — is God. The universe reflects God....There is but one creator and one creation.”

Christian Science

“This creation consists of the unfolding of spiritual ideas and their identities, which are embraced in the infinite Mind and forever reflected. These ideas range from the infinitesimal to infinity, and the highest ideas are the sons and daughters of God.”

References:

Books by Max Kappeler:

Only Science Reveals, (booklet), pp. 5–17.

Recordings by Max Kappeler:

D-4: *Divine Cybernetics and the Self-operating “Dimensional Laws” of the One Being, God*, Series of talks 1971/72 – New York, hour 11B.

Model of Being (The Chart)

Science itself	infinite Principle			
	Word	Christ	Christianity	Science
divine Science	Life	Truth	Love	divine Principle, Love
absolute Christian Science	Life Truth Love	Truth Life Love	Life Love	Truth Love
Christian Science	Mind	Principle Life Truth Love Soul Spirit Mind	Principle Mind Soul Spirit Life Truth Love	Soul — $\begin{matrix} P \\ r \\ i \\ n \\ c \\ i \\ p \\ e \end{matrix}$ — Life Spirit — $\begin{matrix} c \\ i \\ p \\ e \end{matrix}$ — Truth Mind — $\begin{matrix} l \\ e \end{matrix}$ — Love
	Spirit			
	Soul			
	Principle			
	Life			
	Truth			
	Love			

The 7 Synonymous Terms for God (in Word-order): Mind, Spirit, Soul, Principle, Life, Truth, Love

The 4-fold Operation of Being: Word, Christ, Christianity, Science

The 4 Levels of Spiritual Consciousness: Science itself, divine Science, absolute Christian Science, Christian Science

References to the previous matrix: Model of Being“*The Chart*”

Books by Max Kappeler:

The Development of the Christian Science Idea and Practice ©2004, 2nd edition. (healing on the levels)

The Four Levels of Spiritual Consciousness: Science itself, divine Science, absolute Christian Science, Christian Science, pp. 117–198 (the place value of the synonyms on *The Chart*).

Recordings by Max Kappeler:

A-4: *The Structure-principle of Being: Our need for a divine system of reference*, Class 1974 – Wilmington, (DE), hour 21.

A-5: *A Seminar on the 7 Synonymous Terms for God*, Seminar 1975, Wilmington, (DE), hours 22–23.

A-6V: *Syllabus V*, 1980, hours 13–19.

B-2 *From Atomistic Thinking to Cybernetic Comprehensive Consciousness*, Class, 1970 – Ogunquit, (ME), hours 19–20.

D-1: *The 4 Levels of Science*, Series of Talks 1967/68 – London, England, hours 6–9, 13–16.

D-2: *Divine Cybernetics: The proto-science, the integral Science*, Class, 1969 – Braunwald, Switzerland, hours 8–11.

D-4: *Divine Cybernetics and the Self-operating “Dimensional Laws” of the One Being, God*, Series of talks 1971/72 – New York, hours 5–24.

E-1: *The Structure of Being and its Universal Laws*, Max Kappeler, Class, 1973 – New York, hours 7–38.

G-2: *The Science of Being—As I See It Today*, Max Kappeler, Lecture, 1970 – London, England, hour 17.

Books by John Doorly: treated mostly in the context of the ascending and descending scales of Science:

Talks at the Oxford Summer School, 1948, Vol. II, pp. 38, 157–158.

Talks at the Oxford Summer School, 1949, Vol. I, pp. 21–24, 49–51.

Talks at the Oxford Summer School, 1949, Vol. II, pp. 268–273 (the story of the one infinite system, including the level of Science itself).

Talks on the Science of the Bible, Vol. I, “red book,” pp. 65–69.

Talks on the Science of the Bible, Vol. III, “red book,” pp. 282–284.

Talks on the Science of the Bible, Vol. VI, “red book,” pp. 207–208.

Talks on the Science of the Bible, #58, “blue book,” pp. 9–16.

Talks on the Science of the Bible, #59, “blue book,” pp. 4–16 (Christian Science to Science itself to Christian Science).

Talks on the Science of the Bible, #61, “blue book,” pp. 3–10, 31–32.

The Pure Science of Christian Science, pp. 65–67 (the city foursquare and the city of our God).

Model of Being
The Survey

	Word (self-declaration)	Christ (self-operation)	Christianity (self-fulfillment)	Science (self-explanation)
	<i>Father</i>	<i>Son</i>	<i>Mother</i>	<i>Triune Person</i>
divine Science	1. self-existence 2. infinite light 3. infinite individuality	1. self-expression 2. ideal 3. Truth itself	1. all-embracing – All-in-all 2. coexistence of Principle and idea 3. divine Ego	1. divine self-understanding – Holy Ghost 2. harmonious self-government 3. unity of Principle and spiritual power
absolute Christian Science	1. creative impulsion 2. revelation 3. spontaneity – infinite individualities	1. self-realization 2. translation of ideal to idea 3. specific truths – divine Mind-reading	1. each idea reflects Life, Truth, Love 2. demonstration of Life, Truth, Love 3. the compound idea	1. calculus of ideas 2. interpretation 3. spiritual evidence
Christian Science	1. creative thinking 2. ordered understanding 3. laying down the mortal concept	1. manifestation of idea in spite of error 2. retranslation of mortal mind into the divine Mind 3. uncovering of specific error	1. exchanging things for ideas 2. resolving the mortal concept 3. impersonality	1. scientific understanding 2. ideational being 3. proof (error disproved)

References:

Books by Max Kappeler:

The Four Levels of Spiritual Consciousness: Science itself, divine Science, absolute Christian Science, Christian Science, pp. 87–117.

Recordings by Max Kappeler:

A-6V: *Syllabus V*, 1980, hours 11–12.

D-1: *The 4 Levels of Science*, Series of Talks 1967/68 – London, England, hours 10–12, 19B–20.

D-2: *Divine Cybernetics: The proto-science, the integral Science*, Class, 1969 – Braunwald, Switzerland, hours 13–18.

D-4: *Divine Cybernetics and the Self-operating “Dimensional Laws” of the One Being, God*, Series of talks 1971/72 – New York, hours 5B–24.

Word
(self-declaration)

<i>level</i>	<i>John</i>	<i>From “The Survey”</i>	<i>Synonyms for God in “The Chart”</i>
divine Science <i>Principle and idea is one</i>	“the Word was God” (1:1)	<i>Father</i> 1. self-existence 2. infinite light 3. infinite individuality	one Life
absolute Christian Science <i>relationship of Principle to ideas</i>	“all things were made by (the Word)” (1:3)	1. creative impulsion 2. revelation 3. spontaneity ▪ infinite individualities	Life Truth Love
Christian Science <i>relationship of Truth to error</i>	“and the Word was made flesh, and dwelt among us” (1:14)	1. creative thinking 2. ordered understanding 3. laying down the mortal concept	Mind Spirit Soul Principle Life Truth Love

References:

Books by Max Kappeler:

The Four Levels of Spiritual Consciousness: Science itself, divine Science, absolute Christian Science, Christian Science, pp. 93–95, 102–104, 110–112.

Recordings by Max Kappeler:

D-1 *The 4 Levels of Science*, Series of Talks 1967/68 – London, England, hour 19B.

D-2: *Divine Cybernetics: The proto-science, the integral Science*, Class, 1969 – Braunwald, Switzerland, hours 13–14.

D-4: *Divine Cybernetics and the Self-operating “Dimensional Laws” of the One Being, God*, Series of talks 1971/72 – New York, hours 5B–8.

Christ
(*self-operation*)

<i>Level</i>	<i>“Science & Health</i>	<i>From “The Survey”</i>	<i>Synonyms for God in “The Chart”</i>
divine Science Principle and idea is one	“Christ is the son of God” “Christ expresses God’s spiritual eternal nature” (333:9). “Christ ... is the ideal of God” (361:5) “Christ, Truth”	<i>Son</i> 1. Self-expression 2. Ideal 3. Truth itself	Truth
absolute Christian Science Relationship of Principle to idea	“Christ ... is Immanuel or ‘God with us’.” “Christ, the true idea of God” “Christ ... leading into all truth” “Christ ... furnishes us with absolute evidence”	1. Self-realization 2. Translation of ideal to idea 3. Specific truths ▪ Mind-reading	Truth Life Love
Christian Science Relationship of Truth to error	“Christ casts out evils and heals the sick” (143:3) “Christ turns water into wine” “Christ ... improves on a false sense”	1. Manifestation of idea in spite of error 2. Retranslation of mortal mind into the divine Mind 3. Uncovering of specific error	Principle Life Truth Love Soul Spirit Mind

References:

Books by Max Kappeler:

The Four Levels of Spiritual Consciousness: Science itself, divine Science, absolute Christian Science, Christian Science, pp. 95–96, 104–106, 112–113.

Books by John Doorly:

Talks on the Science of the Bible, Vol. VI “red-book,” pp. 210–212 (Christ-vertical in general)..

Recordings by Max Kappeler:

- D-1 *The 4 Levels of Science*, Series of Talks 1967/68 – London, England, hour 19B.
- D-2: *Divine Cybernetics: The proto-science, the integral Science*, Class, 1969 – Braunwald, Switzerland, hours 16–17A.
- D-4: *Divine Cybernetics and the Self-operating “Dimensional Laws” of the One Being, God*, Series of talks 1971/72 – New York, hours 13–15.

Christianity
(Self-fulfillment)

<i>Level</i>	<i>“Science & Health”</i>	<i>From “The Survey”</i>	<i>Synonyms for God in “The Chart”</i>
divine Science Principle and idea is one	“Christianity, with the crown of Love upon her brow:” (451:6) “Christianity ... (is) the demonstration of divine Love.” (135:26) “...perceive Christianity ... in its divine Principle.” (322:7)	<i>Mother</i> 1. All embracing All-in-all 2. Coexistence of Principle and idea 3. Divine Ego	Love
absolute Christian Science Relationship of Principle to ideas	“Christ’s Christianity is the chain of scientific being, ■ reappearing in all ages ... ■ uniting all periods in the design of God” (271:1) “the Science of Christianity ... will lead you into all truth” (271:21) “Christianity, which is the outcome of the divine Principle of the Christ-idea in Christian history” (577:16)	1. Each idea reflects Life, Truth, Love 2. Demonstration of Life, Truth, Love 3. The compound idea	Life Love
Christian Science Relationship of Truth to error	“the surrender of all merely material sensation, affection, and worship. This is the El Dorado of Christianity” (9:19) “There is more Christianity in seeing and hearing spiritually than materially: (487:6) “The nature of Christianity: the anchor of hope must be cast beyond the veil of matter into the Shekinah” (40:32)	1. Exchanging things for ideas 2. Resolving the mortal concept 3. Impersonality	Principle Mind Soul Spirit Life Truth Love

References to the previous matrix: Christianity (*Self-fulfillment*):

Books by Max Kappeler:

The Four Levels of Spiritual Consciousness: Science itself, divine Science, absolute Christian Science, Christian Science, pp. 96–98, 106–107, 114–115.

Recordings by Max Kappeler:

- D-1 *The 4 Levels of Science*, Series of Talks 1967/68 – London, England, hour 19B.
- D-2: *Divine Cybernetics: The proto-science, the integral Science*, Class, 1969 – Braunwald, Switzerland, hour 17.
- D-4: *Divine Cybernetics and the Self-operating “Dimensional Laws” of the One Being, God*, Series of talks 1971/72 – New York, hours 17B–20.

Science
(Self-explanation)

<i>Level</i>	<i>“Science & Health”</i>	<i>From “The Survey”</i>	<i>Synonyms for God in “The Chart”</i>
divine Science <i>Principle and idea is one</i>	“our church is built on the divine Principle, Love” (35:20)	Triune Person 3. Divine self-understanding - Holy Ghost 4. Harmonious self-government 5. Unity of Principle and spiritual power	divine Principle, Love
absolute Christian Science <i>relationship of Principle to ideas</i>	definition of ‘church’: “the structure of Truth and Love” (583:12)	1. Calculus of ideas 2. Interpretation 3. Spiritual evidence	Truth Love
Christian Science <i>relationship of Truth to error</i>	definition of ‘church’: “whatever rests upon and proceeds from divine Principle” (583:13)	1. Scientific understanding 2. Ideational being 3. Proof (error disproved)	Principle Soul ———— Life Spirit ———— Truth Mind ———— Love Principle

References:

Books by Max Kappeler:

The Four Levels of Spiritual Consciousness: Science itself, divine Science, absolute Christian Science, Christian Science, pp. 98–101, 107–109, 115–117.

Recordings by Max Kappeler:

- D-1 *The 4 Levels of Science*, Series of Talks 1967/68 – London, England, hour 20.
- D-2: *Divine Cybernetics: The proto-science, the integral Science*, Class, 1969 – Braunwald, Switzerland, hour 18.
- D-4: *Divine Cybernetics and the Self-operating “Dimensional Laws” of the One Being, God*, Series of talks 1971/72 – New York, hours 22–23.

Divine Cybernetic Model

Science itself				
	Word	Christ	Christianity	Science
divine Science	input	process	output	feedback
	self-organizing			
absolute Christian Science	positive feedback			
Christian Science	negative feedback			

divine cybernetics presents:

- Science itself the one infinite Being
- divine Science as a self-organizing system,
 running on a self-regulating
 circuit
- absolute Christian Science that has positive feedback
 (is error-preventing)
- Christian Science as well as negative feedback
 (is error-correcting)

Recommended references for studying this subject:

Recordings by Max Kappeler:

B-2: *From Atomistic Thinking to Cybernetic Comprehensive Consciousness*, Class, 1970 – Ogunquit, (ME), hour 20B.

D-2: *Divine Cybernetics: The proto-science, the integral Science*, Class, 1969 – Braunwald, Switzerland, hours 1–6, 11B (the class goes on to explain The Model of Being in the light of the cybernetic concept: hours 7–20).

G-2: *The Science of Being—As I See It Today*, Lecture, 1970 – London, England, hours 7B–8.

X-15: *Divine Cybernetics*, mini recording from B-1, #9–10.

Books by Max Kappeler:

The Four Levels of Spiritual Consciousness: Science itself, divine Science, absolute Christian Science, Christian Science, p. 49.

The Dimensional Structuring of the Ideas of the Seven Synonyms for God

On the basis of the levels of Science, the ideas of the seven synonyms for God can be dimensionally ordered, showing how the synonyms themselves appear on each level. Considering the levels in the descending way, we can distinguish definite categories:

Science itself:

- I. *What is the synonym as itself?* i.e., What does the synonym know about itself as itself, as the synonym as such, or as a whole?

divine Science

- II. *What is the synonym in its own realm?* Here the focus is on those ideas that express the universal realm of the synonym, its whole sphere of self-expression, all that the synonym includes within its own domain.

absolute Christian Science

- III. *What is the synonym in relation to its creation?* The focus is no longer on the universal oneness of Principle and idea, but on the ideas themselves and how ideas express the infinite relationships within Being.

Christian Science

- IV. *In what form does the synonym come to the human?* When the divine touches the human, it translates itself in such a way that it is reflected in the human, showing the coincidence of the divine and the human.
- V. *What does the synonym do in the realm of its suppositional opposite?* When the divine has an impact on the human (IV), whatever is unlike God must simultaneously yield. The healing, redeeming process takes place, as something is corrected in the human.
- VI. *What higher attitude does the synonym bring forth in the human?* When that which is unlike God in us gradually yields to the divine (V), something better and higher is brought about in the human; we manifest a higher humanhood through an attitude and consciousness that reflects the divine.
- VII. *How does the synonym appear when it is not understood?* When the entire process of translation (I-VI) is resisted through a lack of understanding, the synonym appears to us in the form of its suppositional opposite. The counterfeit-concept is therefore always the synonym itself, but in misunderstood form.

References:

Books by John W. Doorly:

The Seven Synonymous Terms for God, Chapter 7.
The Science of the Oneness of Being, Max Kappeler, pages 53–63.

Recordings by Max Kappeler:

A–6V: *Syllabus V*, hours. 20–26 (also listed separately as M–16).

MIND

What is it as itself?	What is it in its own realm?	What is it in relation to its creation?	In what form does it come to the human?	What does it do in the realm of its suppositional opposite?	What higher attitude does it bring forth in the human?	How does it appear when it is not understood?
I	II	III	IV	V	VI	VII
the one Mind All The first basis primordial conception (light) intelligence divine will power – force	parent Mind All-in-all – unsearchable – unfathomable realm of ideas – image – metaphysics information – all-knowing – comprehends all – perceives all – apprehends all – all-hearing – all-seeing all-action law	cause – origin – author – source mandate creative impulse creator – creates – makes – produces manifests emanation – proceeds from – flows forth forms – shapes – models – fashions Mind-reading maintains – supports imparts	illumination – vision – enlightenment – gives insight – brings light – discovery wisdom bestows – capacities guides – leads, directs helps influence stimulates unerring governs	controls – regulates medicine heals – saves corrects	true desire poor in spirit – open thought – no preconceptions turning to God being a willing disciple seeking learning – investigating – searching – studying logical reasoning to have the Mind of Christ courage – acting boldly law-abiding divine thoughts true knowledge of God	mortal mind – illusions intelligent matter animal magnetism agnosticism

SPIRIT

What is it as itself?	What is it in its own realm?	What is it in relation to its creation?	In what form does it come to the human?	What does it do in the realm of its suppositional opposite?	What higher attitude does it bring forth in the human?	How does it appear when it is not understood?
I	II	III	IV	V	VI	VII
the only substance – somethingness reality nature good	likeness order rhythm understanding calculus infinite reflection	like produces like gives birth brings forth diversifies – classifies – individualizes orders all unfoldment – development specific reflections focal point	positive – spiritually tangible purity strength spiritual qualities progress – improvement – success – bears fruit spiritual evolution brings understanding	allows no mingling line of demarcation separates – excludes leaven – alchemy leads the warfare dechemicalizes – crisis – subdues purifies	to have but <u>one</u> God uncompromising trust in Spirit discernment turning to Spirit turning away from matter mourning striving worship – focusing on Spirit putting first things first spiritual affections spiritualization gratitude patience	evil – the negative duality – opposites mingling matter – substance materialism the flesh spirits spiritualism polytheism

SOUL

What is it as itself?	What is it in its own realm?	What is it in relation to its creation?	In what form does it come to the human?	What does it do in the realm of its suppositional opposite?	What higher attitude does it bring forth in the human?	How does it appear when it is not understood?
I	II	III	IV	V	VI	VII
divine Ego infinite within-ness identity unchangeable immortality sinless self-sameness I Am that I Am	unlimited – never “in” anything capacity – nothing ever lost inviolable – untouchable – intact rule balance	translates Principle to its idea reproduces itself identifies – defines never without its representative the seed within itself self-regulating	spiritual understanding – spiritual sense – Soul-sense testifies to the spiritual gives divine mission – makes definite – names spiritually true selfhood freedom gives security – safety – stability – certainty – surety joy – happiness – satisfaction	master the greater controls the lesser rebukes – rejects reverses – transforms – retranslates exchanges objects of sense for ideas of Soul reforms resurrects restores leads from sense to Soul	humility meekness self-abnegation – unselfed identifying everything correctly renamed confidence determination constancy – steadfastness perseverance integrity balance beauty – grace	sin – malpractice physical sense-testimony sensations – pain – suffering body souls many egotism counterfeit limitations – “in” something changeable variable pantheism

PRINCIPLE

What is it as itself?	What is it in its own realm?	What is it in relation to its creation?	In what form does it come to the human?	What does it do in the realm of its suppositional opposite?	What higher attitude does it bring forth in the human?	How does it appear when it is not understood?
I	II	III	IV	V	VI	VII
divine Person – Supreme Being the triune Principle – triunity in unity unity of God Science infinite One indivisible whole absolute	the Principle of all all ideas have the same Principle Principle and idea is one interrelated being oneness – indivisibility harmony system – structure – classification self-governing self-organizing ever-operative omni-action	the creative Principle every idea is seen in its Principle inseparable – unity interprets itself as spiritual computations unites all governs “Immanuel”	apodictical – authority – imperative irrefutable spiritual power teaches – explains works out good	never pardons demonstrates proves solves problems	obedience – discipline honesty loyalty impersonality – being principled scientific attitude co-operation	personal sense theories – dogmas – hypotheses – speculations – superstition material knowledge fragmentation arbitrary material organization an anthropomorphic God

LIFE

What is it as itself?	What is it in its own realm?	What is it in relation to its creation?	In what form does it come to the human?	What does it do in the realm of its suppositional opposite?	What higher attitude does it bring forth in the human?	How does it appear when it is not understood?
I	II	III	IV	V	VI	VII
being isness indestructible infinite individuality self-existent	Father nowness – timeless eternal – everlasting – permanency – continuity ever-present – spaceless existence – coexistence self-sustaining fullness – abundance method	fatherhood inexhaustible source provides – maintains spontaneity – impulse multiplication progression	man’s life – supports – sustains gift of grace inspiration newness – mutation the way of Life supplies with ideas love	overcomes death, lack uplifts – exalts above the earthly concept renews – resuscitates – regenerates irrepressible – breaking through irresistible	rarefaction of thought aspiration – soaring rising above corporeality laying down the mortal concept of life merciful follow the way pioneer consecration	mortal life death time destructive lack persecution vitalism

TRUTH

What is it as itself?	What is it in its own realm?	What is it in relation to its creation?	In what form does it come to the human?	What does it do in the realm of its suppositional opposite?	What higher attitude does it bring forth in the human?	How does it appear when it is not understood?
I	II	III	IV	V	VI	VII
divine self-consciousness ideal standard the whole	Son self-claiming self-affirming all-penetrating ever at work form (Gestalt) wholeness factuality right	sonship the compound idea the truth about everything specific truths all-illuminating	the voice of Truth revelation faultlessness unerring establishes the idea in us the true solution effectual gives dominion true manhood – the rights of man health – wholeness divine justice	unveils error uncovers error denies error neutralizes error works out the nothingness of error destroys error – dispels “ – annihilates “ – removes “ – obliterates “ – consumes “ – overcomes “ – conquers “ – quenches “ – casts out “ sets man free – victor healer – redeemer – savior universal remedy alterative	adhering to Truth having dominion affirmation of Truth denial of error claiming the Truth utilization of Truth righteousness uprightness truthfulness pure consciousness – sincerity humanity – brotherliness	error – falsity lie – falsehood denial of Truth contradiction sickness theodicy

LOVE

What is it as itself?	What is it in its own realm?	What is it in relation to its creation?	In what form does it come to the human?	What does it do in the realm of its suppositional opposite?	What higher attitude does it bring forth in the human?	How does it appear when it is not understood?
I	II	III	IV	V	VI	VII
perfection integrated being self-sufficiency	Mother is one with its creation never without its full manifestation never loses sight of loveliness infinite self-containment all-embracing – universal – all-encompassing complete totality plan – design	motherhood inexhaustible riches consummation design – step-by-step execution of the plan goal-directed purposes – aim fulfillment	being included blesses all holiness, glory supports the struggling heart impartial all-ministering – all works together for good imparts all good – gives all – bestows all making man a partaker meets human needs ever-present help rest, peace holiness, glory	ultimatum salvation forces the redemption – chastens forgives all universal solvent – ultimate and final solution excludes error makes error harmless fills every vacuum full compensation – full reward instantaneous healing protects – comforts to Love there is – no error – no accuser – no contest to Love everything is possible instantaneous healing	accepting – welcoming mothering womanhood – woman sense – loving – peaceful – compassion – devotion – impartial – long-suffering – forgiving – confident glorification to be with the Lord universal outlook divine service	non-existence – annihilation fear, hate enmity penalty curse – damnation nihilism

PART III

The Laws of Being

WHAT ARE THE DIVINE LAWS?³

Now, we want to proceed and touch on the great question of law.

We have seen that structure demands structural laws. Therefore, we should ask ourselves, what are the divine laws? Mrs. Eddy uses the term law in the Textbook and in her writings quite often. There is great emphasis on the fact that there are laws. But when you go through all the references and ask yourself what these laws are, you may have difficulty in finding out what these laws are.

Usually it is just stated that there are laws, that there are laws of God, but what they are, Mrs. Eddy does not state so explicitly. We are a bit at sea until we begin to investigate the Textbook in a structured way. Then the laws just jump out of the Textbook, one by one. If a textbook of mathematics says that mathematics has laws and that these laws are eternal, and these laws are good, would we know the laws? Could we calculate? We could not. We would have to know exactly what the elements are of such laws. You would have to be able to define what the elements are, and what the relationships are within a definite law. Only then can we have a clear concept of a law.

This is very difficult to see in the first investigation of the Textbook. Since my university years, I was constantly asking myself, what are those laws of which Mrs. Eddy speaks in the Textbook? One cannot just say there are laws and the laws of God but, nobody knows what the laws of God are. With some few exceptions, Mr. Doorly also did not teach about laws. Actually this question did not arise during his time, and I was very close to Mr. Doorly, especially in the years that were important for the whole development of the idea.

So we can see that, compared to that period of time, even to ask the question about laws was a new paradigm too. It is a question that has always been swept under the carpet. At that time no one was asking: What are the laws? What are these laws of God? Tell me how they are stated. Tell me the elements of each law. Tell me how these laws vary from each other. What is the difference between these laws? These questions were never asked. We have seen that a new paradigm asks new questions. It does not answer the old questions. It asks new questions and, therefore, also has to answer new questions.

For about twenty-five years, I was asking these new questions but did not get a single answer! I did not find any answers until about 1960 when I began to study the Minor Prophets. When I was asking a question about what I felt was an anomaly, I did not sweep it under the carpet. Then I felt it was something that would be very important. From that time on the question of law, and the answers of what laws are, came into focus.

Perhaps you know if you have read my book on the prophetic era, *The Minor Prophets in the Light of Christian Science*,⁴ that I stated every prophet in the form of a law. There I stated the laws in their very clear-cut elements.

That was such a terrific change that nobody understood my book. They read it in the old paradigm of Bible interpretation. Because Mr. Doorly had interpreted the Bible over a period of

³ Max Kappeler, E-1 — *The Structure of Being and its Universal Laws*, 39 hours, © 1973, New York, NY

⁴ Max Kappeler, *The Minor Prophets in the Light of Christian Science*, © 1962

years, and published about six thousand pages on Bible interpretation, that left only very little to his students for interpretation. So when I picked up the little remnants that were left from the Old Testament in a few of the Minor Prophets, they all thought that I was now interpreting the rest that was left over from John Doorly. But I did something completely different.

All those who bought my book just felt that it was nice but, it was the old story of interpreting biblical symbolism as metaphysical symbolism.

That was not the purpose of my book. I was thrilled to discover laws for the first time, and to learn how to formulate laws, and how to state laws within a bigger framework of the Christ matrix. That was the beginning of investigating the question of laws more and more.

We must be aware that this is a new paradigm, that it is asking new questions, and that it is answering new questions. But it also demands a completely different approach to the subject.

Laws of Isness (Being) Laws of Process

There are two big categories of laws which we call the laws of “isness,” or of Being, and the laws of processes. You can state a law about something that *is*, but you also can have laws about something that has a process. These are two big categories.

In Black’s “Law Dictionary,” you will find this definition: “Law is that which is laid down, ordained, or established. A rule or method according to which phenomena or actions coexist.” These would be the “isness” laws. They coexist or follow each other. These would be the laws of process. This is a law that shows how something follows something else, and so on. Whereas the laws of isness just show how phenomena coexist together.

We will examine both categories of laws when we go through the Chart. There we will find laws of isness and we will find laws of process. Webster says that “law is a statement of an order or relation of phenomena ... that, so far as it is known is invariable under the given conditions.”

When we go through those laws, we will have to state the laws in their elements and see that, if we want to apply these laws, we have to adhere to them invariably. We should not try to constantly change them as we are used to doing in religious thinking. They are invariable under the given conditions. For instance, if we are thinking on the level of divine Science, then that is the given condition. We have within that condition, invariable laws. We can find invariable laws for all levels of consciousness.

The Random House “Dictionary of the English Language,” gives another definition, which I feel is one of the best for us. It reads, “The law is a rule, principle or convention regarded as governing the structure or the relationship of an element in the structure of something.” We can see that the law is that which governs the structure. It is a structural law. It is a law that governs the relationship of one element within that whole structure.

Laws: according to Mrs. Eddy⁵

It is interesting to go through the “Concordance”⁶ and look up all the statements Mrs. Eddy makes in “Science and Health,” and in “Prose Works,” on law, and laws. Here are a few quotes to show that she does not actually say very much about it.

If one regards law in relationship to God, which is one of the main characteristics of her writings—we see that she couples law with God—and has four different kinds of relationships, which would be in accordance with the Word, Christ, Christianity and Science.

She says, “God is the lawmaker” (381:151). That would be the Word. In the Christ, she says, God is the “Lawgiver” (Mis. 258:13). He gives the law. In Christianity, she says, “the Lawgiver was the only law of creation” (Mis. 259:14). That is Christianity, the universe, the law of creation. And in Science, she says, “God is ... the only law of being” (Mis. 17).

If you analyze these statements about God and law, you still do not know very much. You only know that God makes laws, and that God gives law, and that the creation of God has laws and that is the law of being. Yet you do not know the first thing about what these laws are. These quotes are not really revealing very much. She even makes that very important statement that God was “a law to Himself” (Mis. 258:13). Perhaps that statement can give us a clue of how to go about finding hidden laws embedded in “Science and Health.”

Even when we ask what the connection is between law, the laws of God and Science—because we had a feeling that law had to do with Science—one does not really get a great measure of information. Mrs. Eddy just says, “Science is the law of God” (My. 347:24). So you get a little bit more information instead of just saying that God is the lawmaker and the lawgiver.

Mrs. Eddy says that the law of God is really Science, and that naturally builds a bridge, to the realization that the whole realm of Science is the law of God. But Science is a big field. It consists of system, categories, structures, and so on. But she also says that “Christian Science is the law of God...” It is not only Science. She continues, saying, “...interpreting and demonstrating the divine Principle and rule of universal harmony” (Rud. 1:2).

The moment Mrs. Eddy combines the law of God with Christian Science, then she means that these laws will be those laws that regulate the relationship of the divine Principle with the demonstration and interpretation of that Principle, bringing out the harmony of being.

⁵ Max Kappeler, *A Study Aid for the Science of Christian Science*, ©2016, pp. 130-131.

⁶ *A Complete Concordance to the Writings of Mary Baker Eddy*, published by The Trustees Under the Will of Mary Baker Eddy. Boston, MA. 1908.

The Laws of the ‘Model of Being’

Law of Science itself:

- *the law of infinite Being*
- The law of infinite self-reflection

Law of divine Science:

- *the law of divine self-organization*
- the law of divine cybernetics

Law of absolute Christian Science:

- *the law of divine spontaneity*
- the law of divine self-regulation

- Word:*
- *the law of divine impulsion*
 - the law of divine success-mechanism
 - the law of mutation
 - the law of the divine surprise
 - the law of infinite progression
 - the law of eternal newness

- Christ:*
- *the law of individualization*
 - the law of divine specialization
 - the law of infinite adaptation
 - the law of divine selectioning

- Christianity:*
- *the law of eternalization*
 - the law of self-maintenance
 - the law of divine reproduction

- Science:*
- *the law of prestabilized perfection*
 - law of perfect preformation

Law of Christian Science:

- *the law of divine causality*
- the law of divine self-correction of error

- Word:*
- *the law of creativity*
 - the law of divine illumination
 - the law of ordered evolution

- Christ:*
- *the law of translation and retranslation*
 - the law of transformation and reformation
 - the law of irresistible manifestation

- Christianity:*
- *the law of reflection*
 - the law of demonstration
 - the law of the self-annihilation of error

- Science:*
- *the law of structured understanding*

Laws of interdependence:

- between divine Science (dSc) and absolute Christian Science (aCS) in Word, Christ, Christianity, and Science
- between absolute Christian Science (aCS) and Christian Science (CS) in Word, Christ, Christianity, and Science

Laws of the synonyms for God:

Mind:	law as such
Spirit:	the ordering law
Soul:	the ruling law
Principle:	the law of government
Life:	the law of renewal
Truth:	the law of self-realization, of healing
Love:	the law of fulfillment

structural laws:

- law of integral oneness
- law of invariance
- law of fundamental translatability
- law of hierarchical order
- law of self-regulation (= divine cybernetics)
- law of dynamic equilibrium
- law of complementarity
- law of synergy

References:

Recordings by Max Kappeler:

E-1: *The Structure of Being and its Universal Laws*, Max Kappeler, Class, 1973 – New York, 39 hours.

G-7: *The Law of the Self-evolution of Understanding Through the Idea of Christian Science*, Max Kappeler, Class, 1994 – New York, 27 hours.

The Law of Being Law is a Principle of Being

The law of the integral Oneness and Wholeness of Being

- integral: constituting the whole
- parts do not exist, *per se*
- holism: the whole is greater than the sum of its parts
 - oneness is only possible through structural laws
 - structural laws result in meaningful wholeness
- chance, wonder, chaos: unknown laws of a higher order

The law of hierarchical order of all laws

- translation of the One into the many
- every level has its own laws; these are secondary
- every level implies the other levels
- Beware: not to mix the levels

The law of fundamental translatability (transformation laws)

- ascending: overforming of misunderstanding to understanding the infinite One
- descending: translation of the infinite One to the point of resolving misunderstanding

The law of self-organization: divine cybernetics

- self-organizing
- self-structuring
- self-regulating
- self-correcting (mistake-friendly)

The law of optimizing

- feedback: spiraling higher and higher

The law of synergy

- dynamic cooperation of various structural laws or cybernetic laws

The law of complementarity

- the “as well as” law
- (Mary Baker Eddy: ‘No and Yes’)
- (quantum theory)

The law of dynamic equilibrium

- equilibrium in spite of change
- “the Science which governs these changes” (S&H 224:6)
- homeorhesis: stability in change

The law of redundancy

- reduction of the many to the few
- categorizing

References:

Recordings by Max Kappeler: G-7: *The Law of the Self-evolution of Understanding Through the Idea of Christian Science*, Max Kappeler, Class, 1994 – New York, 27 hours.

The law on the level of Science itself
the law of infinite Being

- I. *pedal note:* I Am that I Am
the infinite One
Being itself, indivisible Being
- II. *factors of the law:* Being (I Am)
relationship
to itself (= Being)
- III. *law:* $\underbrace{\text{Being}}_1 \quad \underbrace{\text{is its own infinite}}_2 \quad \underbrace{\text{Being}}_3$
- IV. *application:* M → Lo is its own infinite M → Lo
(7 x 7 = 49)
- V. *criteria:* a) isness vs. operational sense
b) no time or space sense
c) no human or material connotation,
no anthropomorphic sense

Mind	power intelligence basis	Principle	Science structure
Spirit	substance reality the only nature	Life Truth	isness individuality consciousness whole standard
Soul	identity Ego	Love	perfection self-completeness

References:

Books by Max Kappeler:

general:

The Four Levels of Spiritual Consciousness: Science itself, divine Science, absolute Christian Science, Christian Science, pp. 119–127.

Recordings by Max Kappeler:

E-1: *The Structure of Being and its Universal Laws*, Max Kappeler, Class, 1973 – New York, hours 7–9A.

Books by John Doorly: *the level of Science itself in*

Talks on the Science of the Bible, #59 “blue-book,” pp. 5, 14, 15.
Talks on the Science of the Bible, #60 “blue-book,” p. 32.
Talks on the Science of the Bible, #61 “blue-book,” pp. 3–10, 31–32.
Talks at the Oxford Summer School, 1949, Vol. II, pp. 268–273.

The laws on the level of absolute Christian Science
the law of spontaneity

The derivation of the laws from the level of Science itself:

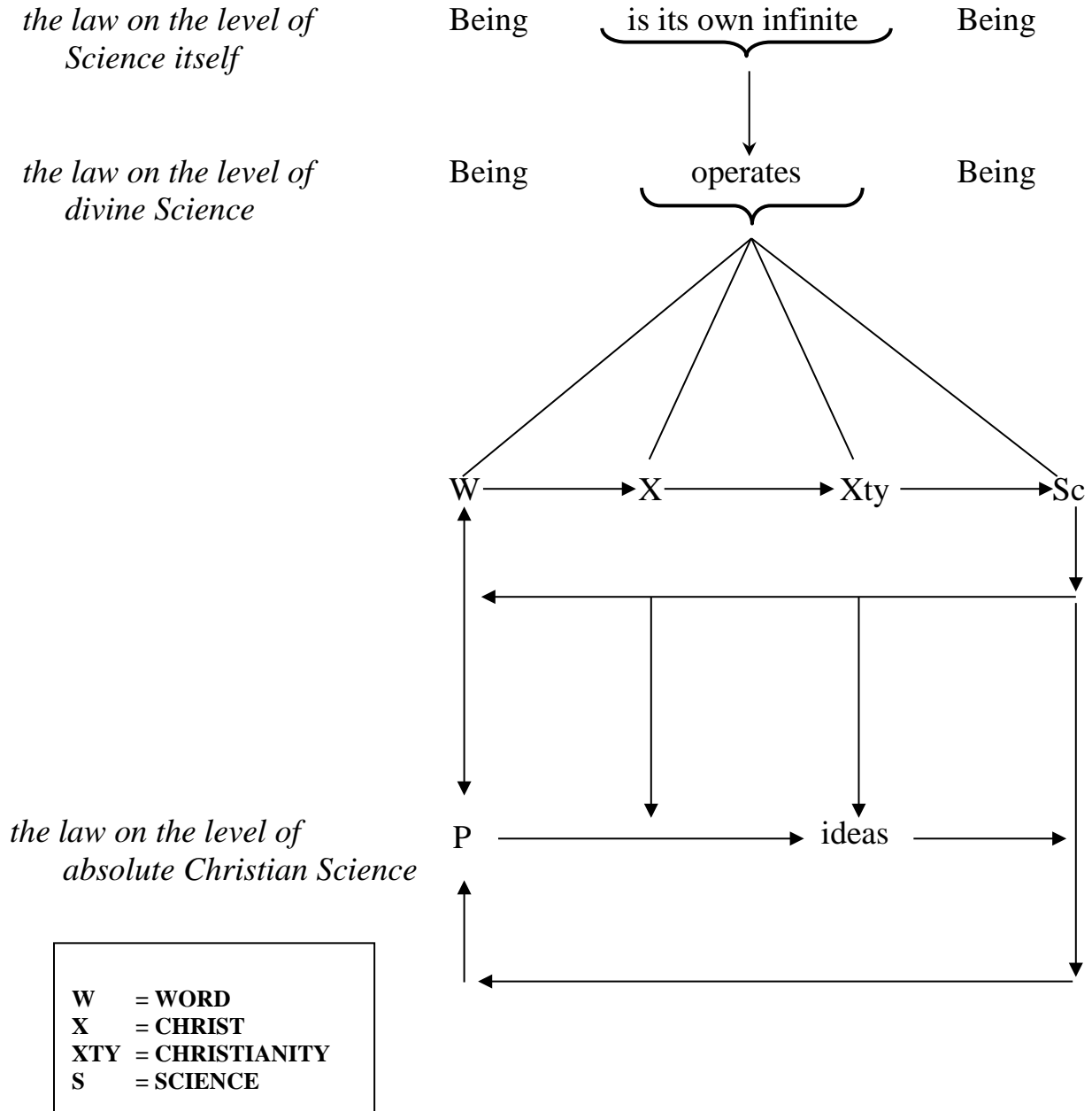

References:

Books by Max Kappeler:

The Four Levels of Spiritual Consciousness: Science itself, divine Science, absolute Christian, Science, Christian Science, pp.168–169 (divine laws of Life, Truth, and Love on the level of absolute Christian Science).

Recordings by Max Kappeler:

E-1: *The Structure of Being and its Universal Laws*, Class, 1973 – New York, hours 12B–14.

The law of “The Word” on the level of absolute Christian Science
the law of divine impulsion
(law of divine success-mechanism)

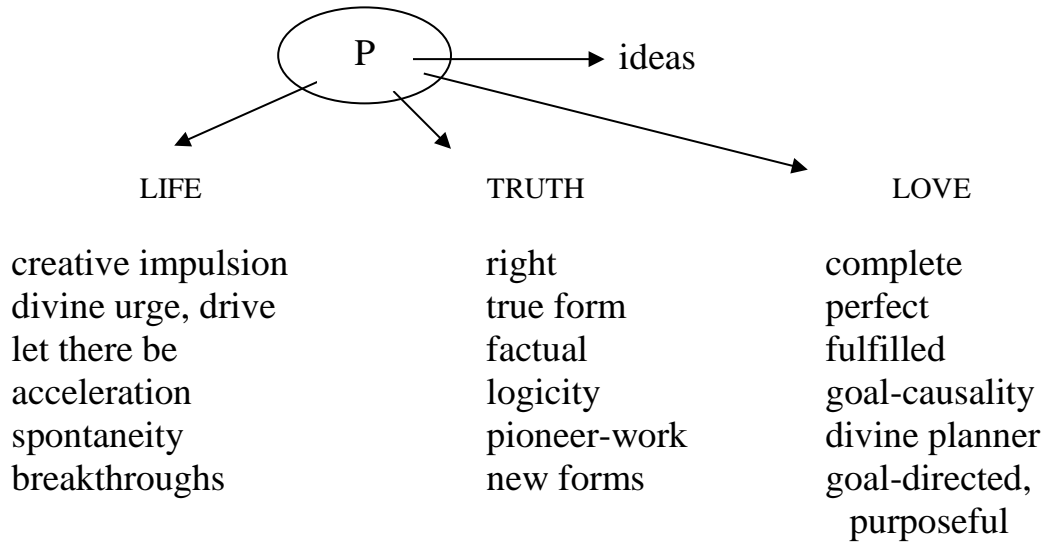

References:

Books by Max Kappeler

The Four Levels of Spiritual Consciousness: Science itself, divine Science, absolute Christian Science, Christian Science, pp. 154–157.

Recordings by Max Kappeler

- E-1: *The Structure of Being and its Universal Laws*, Max Kappeler, Class, 1973 – New York, hour 13A.
- D-4: *Divine Cybernetics and the Self-operating “Dimensional Laws” of the One Being, God*, Series of talks 1971/72 – New York, hour 7.

I. The law of “The Christ” on the level of absolute Christian Science
the law of divine individualization
(law of specification)

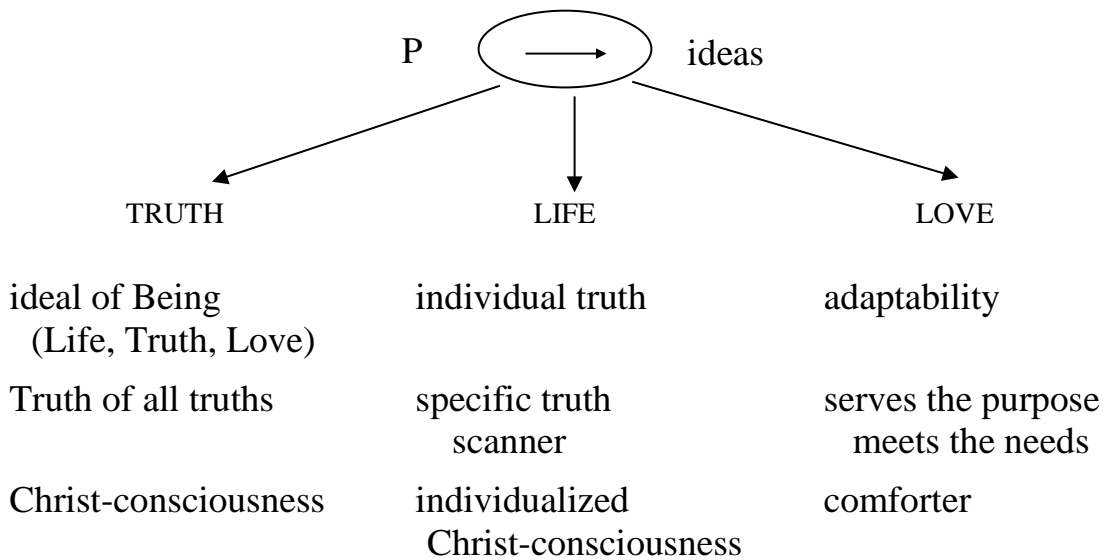

References:

Books by Max Kappeler

The Four Levels of Spiritual Consciousness: Science itself, divine Science, absolute Christian Science, Christian Science, pp. 157–161.

Recordings by Max Kappeler

- E-1: *The Structure of Being and its Universal Laws*, Max Kappeler, Class, 1973 – New York, hour 13B.

II. The law of “Christianity” on the level of absolute Christian Science
the law of eternalization
(law of self-maintenance)

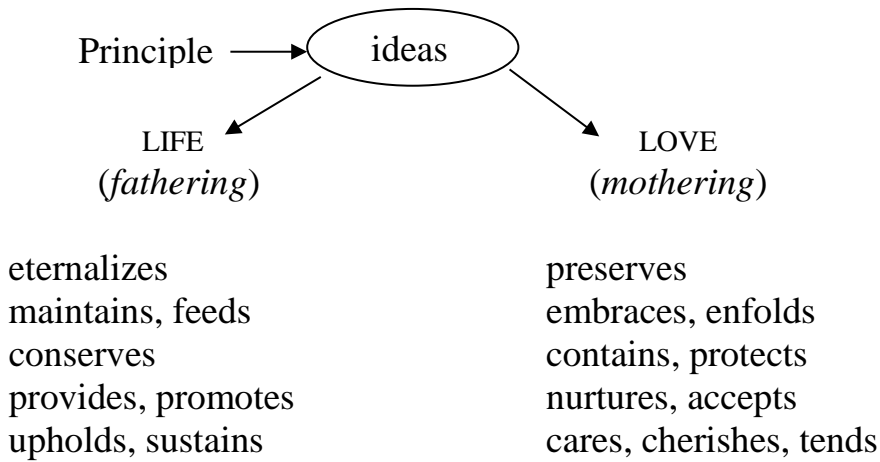

References:

Books by Max Kappeler

The Four Levels of Spiritual Consciousness: Science itself, divine Science, absolute Christian Science, Christian Science, pp. 162-166.

Recordings by Max Kappeler

- E-1: *The Structure of Being and its Universal Laws*, Max Kappeler, Class, 1973 – New York, hour 14A.
- D-4: *Divine Cybernetics and the Self-operating “Dimensional Laws” of the One Being, God*, Series of talks 1971/72 – New York, hour 19.

The law of “Science” on the level of absolute Christian Science
the law of prestabilized perfection
(law of pre-established harmony)

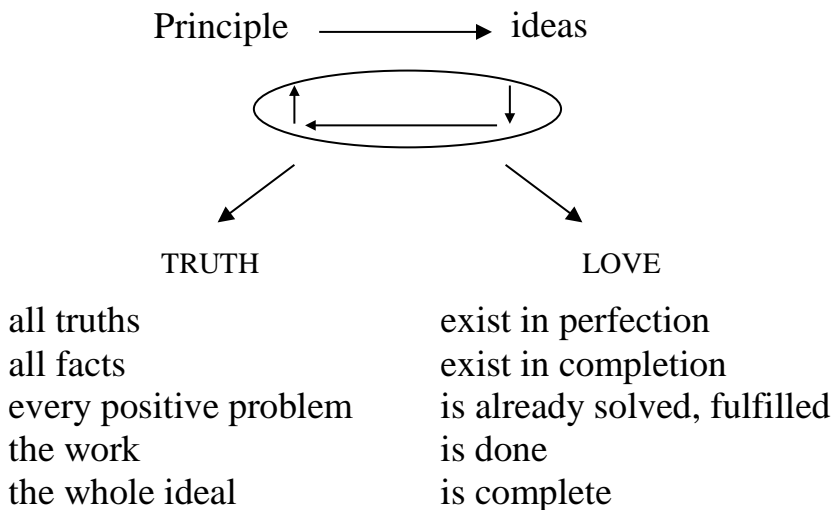

References:

Books by Max Kappeler

The Four Levels of Spiritual Consciousness: Science itself, divine Science, absolute Christian Science, Christian Science, pp. 166-168.

Recordings by Max Kappeler

- E-1: *The Structure of Being and its Universal Laws*, Max Kappeler, Class, 1973 – New York, hour 14B.

**The laws of interdependence between
absolute Christian Science and Christian Science**

The law of interdependence in the Word

the law

the elaboration of the law

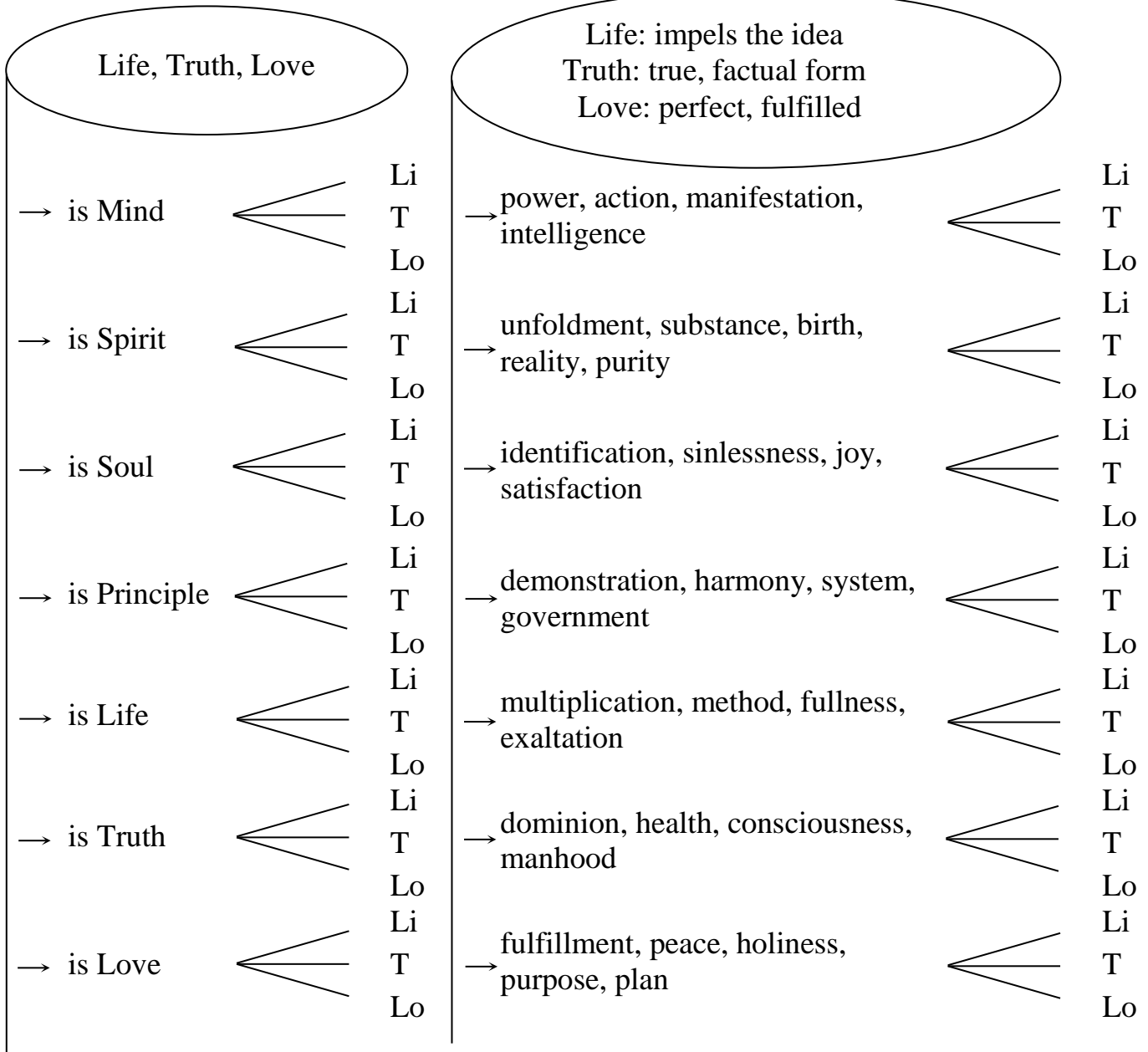

References to the previous diagram “The laws of interdependence between absolute Christian Science and Christian Science, *The law of interdependence in the Word*”:

Books by Max Kappeler:

The Four Levels of Spiritual Consciousness: Science itself, divine Science, absolute Christian Science, Christian Science, pp. 169–174.

Recordings by Max Kappeler:

A-6V: *Syllabus V*, 1980, hours 18–19A

D-2: *Divine Cybernetics: the proto-science, the integral Science*, Class, 1969 – Braunwald, Switzerland, hours 14B–15.

D-4: *Divine Cybernetics and the Self-operating “Dimensional Laws” of the One Being, God*, Series of talks 1971/72 – New York, hour 11.

E-1: *The Structure of Being and its Universal Laws*, Class, 1973 – New York, hour 24B–25.

G-2: *The Science of Being—As I See It Today*, Lecture, 1970 – London, England, hour 7.

X-15: *Divine Cybernetics*

Books by John W. Doorly:

Talks at the Oxford Summer School, 1949, Vol. I, pp. 9, 18–21, 31–48 (in the Word).

**Elaboration of the law of interdependence in “The Word”
through the fourfold operation**

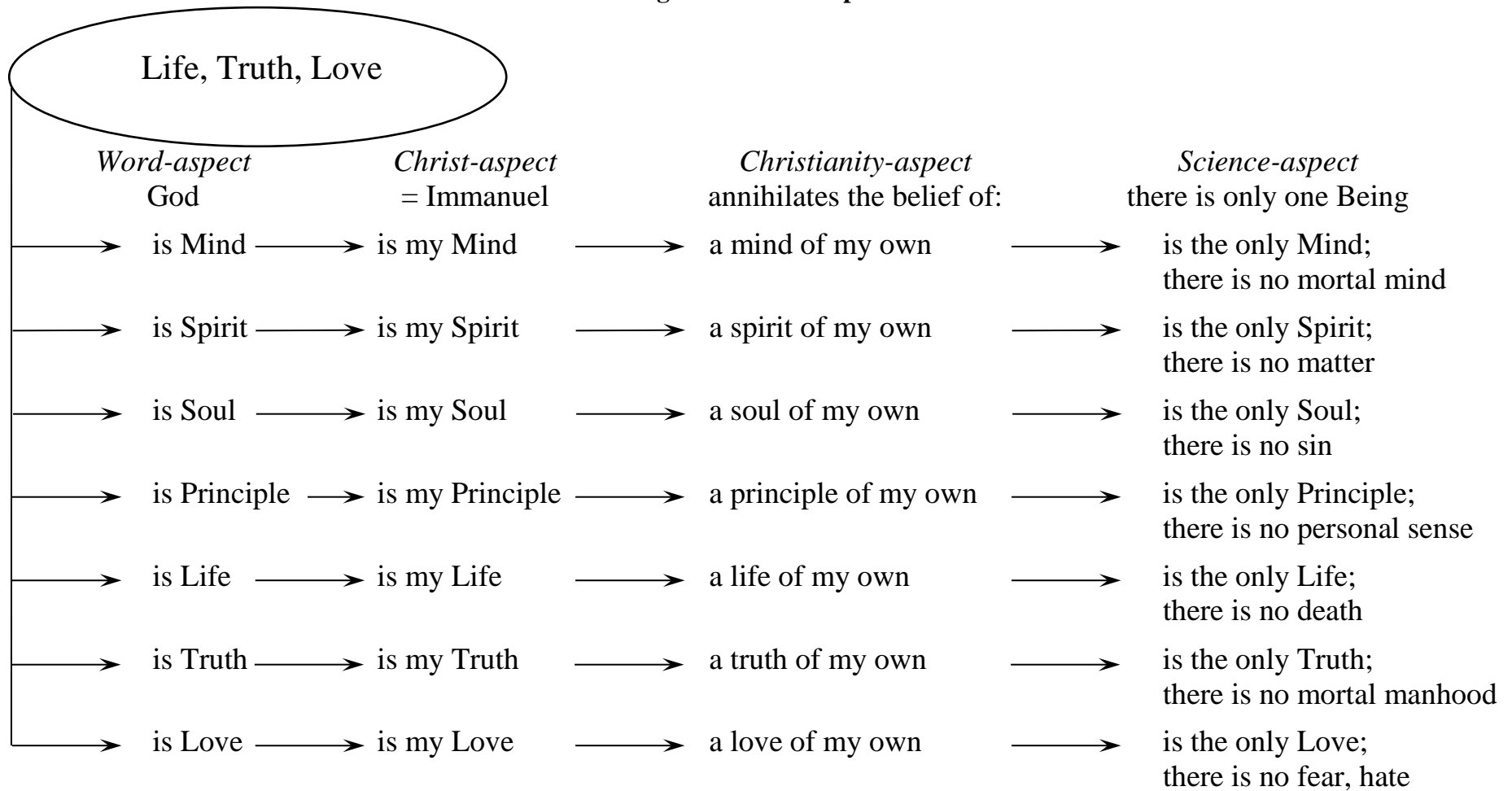

References:

Recordings by Max Kappeler:

A-6V: *Syllabus V*, 1980, hour 19.

D-4: *Divine Cybernetics and the Self-operating “Dimensional Laws” of the One Being, God*, Series of talks 1971/72 – New York, hour 12.

E-1: *The Structure of Being and its Universal Laws*, Class, 1973 – New York, hour 25B.

The law of interdependence in the Word
 illustrated through the seven days of creation
(Gen. 1:3–2:2)

Day of Creation	Life: The Creative	Truth: The Factual	Love: The Fulfilled
1 st Day	Let there be light (1:3)	And God divided the light from the darkness (1:4)	And God called the light Day (1:5)
2 nd Day	Let there be a firmament (1:6)	And God made the firmament (1:7)	And God called the firmament Heaven (1:8)
3 rd Day	Let the dry land appear (1:9, 10)	Let the earth bring forth grass, and herb yielding seed, and the fruit tree yielding fruit after his kind, whose seed is in itself (1:11)	And the earth brought forth grass, and herb, and the tree yielding fruit (1:12, 13)
4 th Day	Let there be lights ... for signs and for seasons and for days, and years ... to give light on the earth (1:14, 15)	God made two great lights ... to rule the day and the night (1:16)	God set them in the firmament of the heaven ... to rule (1:17–19)
5 th Day	Let the waters bring forth abundantly the moving creature that hath life (1:20)	God created great whales, and every living creature that moveth ... and every winged fowl (1:21)	God said, be fruitful and multiply (1:22, 23)
6 th Day	Let the earth bring forth the living creature (1:24, 25)	Let us make man in our image, after our likeness. God created man in His own image (1:26, 27)	Be fruitful, and multiply ... and have dominion (1:28–31)
7 th Day (as Truth) (as Love)	Heavens... (2:1) On the seventh day God ended... (2:2)	And earth... (2:1) ...His work which He had made... (2:2)	and all the hosts of them were finished (2:1) ...And he rested ... from all His work (2:2)

References:

Recordings by Max Kappeler:

- C-1G: *CH. XV., Genesis, The Structure of the Christian Science Textbook—Our Way of Life*, Series of Talks: 1981, hours 10B, 15.
- D-4: *Divine Cybernetics and the Self-operating “Dimensional Laws” of the One Being, God*, Series of talks 1971/72 – New York, hours 11–12.

Books by John Doorly:

- Talks at the Oxford Summer School 1949*, Vol. I, pages 7–48.

St. Matthew

The law of interdependence in the Word illustrated through the layout of St. Matthew

The seven stages of unfoldment (Christian Science)
from the standpoint of Life, Truth, and Love (absolute Christian Science)

- MIND** Life, Truth, and Love manifest the divine Parent-Mind and thus bring to light the true idea of man (Matt. 1:1–2:23).
- Life: Under the impulsion of Life, the creative Mind manifests uninterruptedly its own idea (Matt. 1:1–17).
- the genealogy of Jesus (“...begat ... begat”)
- Truth: The idea which is brought forth by the impulsion of Life is the idea of Truth: the saving Christ-idea (Matt. 1:18–25).
- Mary’s conception of Jesus (= Savior)
- Love: Love protects the idea from the assaults of mortal mind (Matt. 2:1–23).
- the wise men—escape to Egypt—
Herod—return to Nazareth
- SPIRIT** Life, Truth, and Love unfold, through the baptism of Spirit, the idea of man purified from all mortal beliefs (Matt. 3:1–17).
- Life: The inspiration and exaltation of Life arouses in man the desire for the things of Spirit (Matt. 3:1–9).
- the baptism of repentance
- Truth: The factuality of Truth resolves all that is wrong in man and lets only that which is true unfold in him (Matt. 3:10–11).
- the baptism of the Holy Ghost
- Love: The perfection of Love brings forth in an ordered way the purely spiritual identity of man (Matt.3:12–17).
- the baptism of Spirit
- SOUL** Life, Truth, and Love impel the true identification of man (Matt. 4:1–22).
- Life: Life identifies itself in man as his only provider and maintainer (Matt. 4:1–7).
- 1st temptation (to turn stones into bread)
 - 2nd temptation (pinnacle of the temple:
“cast thyself down”)

St. Matthew (cont.)

Truth: The Christ-Truth in man rejects sin and affirms the divine identity of man (Matt. 4:8–11).
– 3rd temptation (“Get thee hence, Satan”)

Love: Love makes each one become conscious of their universal identity (Matt. 4:12–22).
– Jesus calls the disciples and makes them fishers of men

PRINCIPLE Life, Truth, and Love reveal the interpretation of the Science of man (the Sermon on the Mount) (Matt. 4:23–7:29).

Life: Life impels the divine Principle to interpret itself to man in an ordered way as a healing Science (Matt. 4:23–5:9).
– Jesus healed all manner of disease
– The Beatitudes (“blessed are...”)

Truth: Truth demands “Christ-Science” instead of “right thinking” in order to establish harmony in man (Matt. 5:10–48).
– Jesus’ teaching versus human opinions

Love: Love fulfills the Science of man through the Science of Life and the Science of the one Being (Matt. 6:1–7:29).
– Jesus teaches the Science of Life, a new style of life, in contrast to a hypocritical life (Matt. 6:1–7:12).
– Jesus teaches the Science of Being (Matt. 7:13–29)

LIFE Life, Truth, and Love demonstrate the fullness of life (Matt. 8:1–14:36).

Life: The impulsion of Life demonstrates the fullness of life individually (Matt. 8:1–9:8).
– individual healings through Life-power

Truth: The acknowledgment and affirmation of the Christ-Truth in man has a regenerating and resurrecting effect (Matt. 9:9–9:38).
– individual experiences in which the Christ-consciousness in the patient is appealed to, and thus a new sense of life is affirmed Love: Love bestows a full measure of life, which fulfills itself in every detail (Matt. 10:1–14:36).
– Jesus sends out his twelve apostles
– seven parables of the kingdom of heaven (a fulfilled state)
– feeding of the 5000

St. Matthew (cont.)

TRUTH Life, Truth, and Love establish true manhood as a divine calculus of ideas (Matt. 15:1–25:46).

Life: The impulsion of Life establishes the calculus of ideas in place of human calculations and opinions (Matt. 15:1–25:46).

- the commandments of God versus the tradition of the elders
- feeding of 4000
- to know the signs of the times
- the leaven of the Pharisees
- Who is the Son of man?

Truth: The Christ-Truth (the divine calculus) has dominion over the human (the mortal calculus) and thus translates the human back into the divine (Matt. 16:21–19:15).

- “Get thee behind me, Satan.”
- mount of transfiguration.
- Who is the greatest? — “whoever shall humble himself.”
- to save that which was lost
- to forgive seventy times seven

Love: In the all-embracing Love, the divine calculus resolves the mortal calculus completely (Matt. 19:16–25:46).

- Being is indivisible and therefore all mortal concepts have to be laid down (Matt. 19:16–20:34).
- the wholeness of the idea (Matt. 21:1–46)
- complete devotion to the Christ-consciousness (Matt. 22:1–23:39)
- the self-destruction and nothingness of error (Matt. 24:1–25:46)

LOVE Life, Truth, and Love bring true manhood to fulfillment; no error can prevent salvation (Matt. 26:1–28:20).

(a) In the face of error

Life: The impulsion of Life enforces the complete disappearance of the mortal concept of man (Matt. 26:1–26:46).

- Bethany—Last Supper—Gethsemane

Truth: The whole gamut of error cannot touch the factuality of the Son of God (Matt. 26:47–27:44).

- Judas’ kiss—Jesus before the high priest—
- the denial by Peter—Pilate—crucifixion

St. Matthew (cont.)

Love: Love fulfills itself in the victory of the Son of God over every error (Matt. 27:45–61).
– darkness—veil of temple rent—earthquake
– rocks rent—graves opened

(b) In the oneness of Being

Life: The irrepressible impulsion of Life proves that the life of man is deathless (Matt. 27:62–28:8).

– Jesus’ resurrection.

Truth: The true form of the Son of God is an unchangeable fact (Matt. 28:9–17).

– Jesus reappears to his disciples.

Love: The design of Love is fulfilled: the universality of the Son of God (Matt. 28:18–20).

– “All power is given unto me in heaven and in earth.”

– “I am with you alway, even unto the end of the world.”

References:

Recordings by Max Kappeler

- D-4: *Divine Cybernetics and the Self-operating “Dimensional Laws” of the One Being, God*, Series of talks 1971/72 – New York, hour 11B–12.
E-1: *The Structure of Being and its Universal Laws*, Class, 1973 – New York, hours 26–29.

Books by John W. Doorly

Talks at the Oxford Summer School, 1949, Vol. I, pp. 49–140, Appendix: “Plan of the Gospel of Matthew.”

Summary of the law of interdependence in "The Word"
Illustrated through the layout of "St. Matthew"

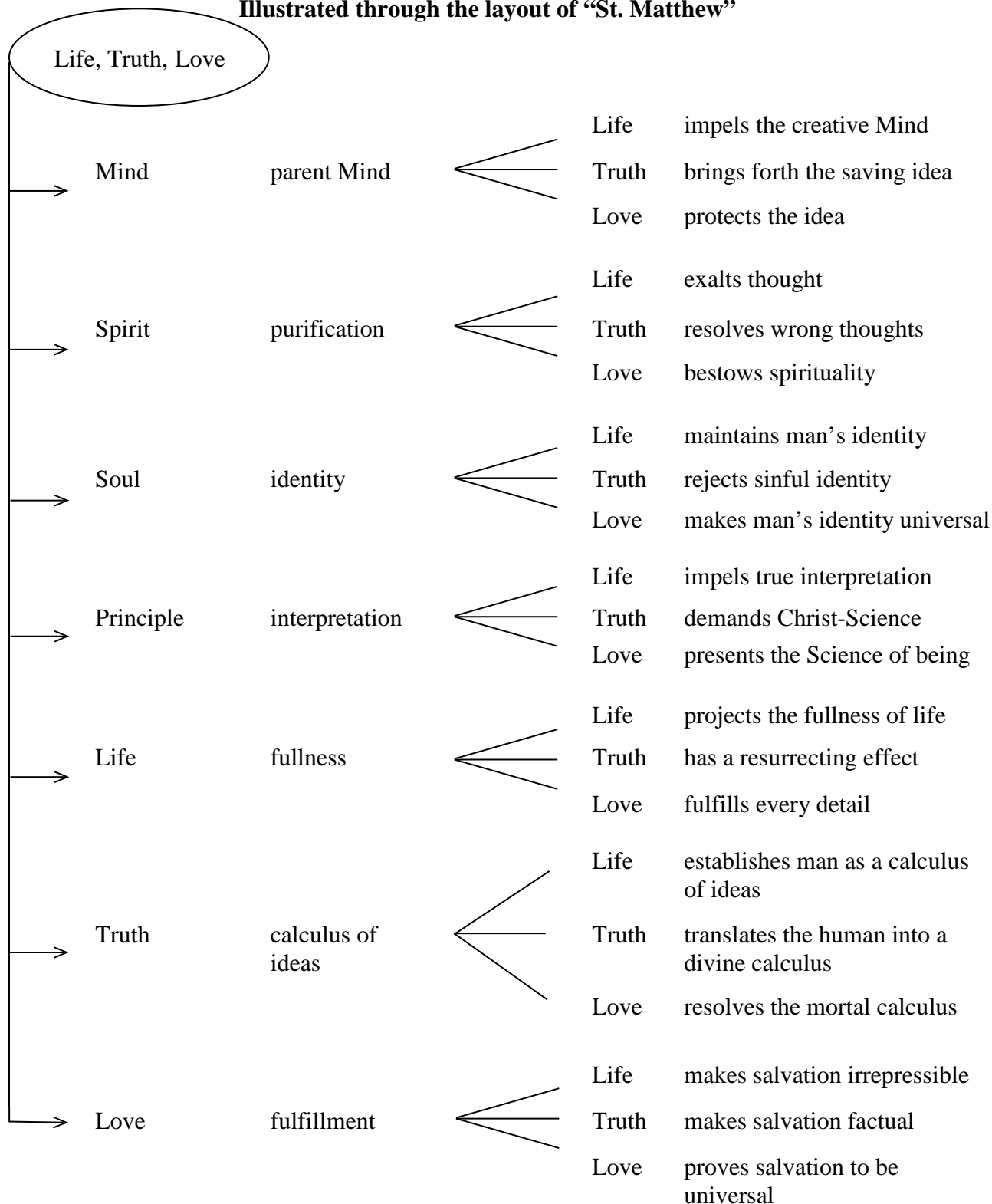

References to the diagram, “Summary of the law of interdependence in *The Word Illustrated* through the layout of *St. Matthew*”:

Recordings by Max Kappeler:

D-2: *Divine Cybernetics: The proto-science, the integral Science*, Class, 1969 – Braunwald, Switzerland, hour 15B.

D-4: *Divine Cybernetics and the Self-operating “Dimensional Laws: of the One Being, God*, Series of talks 1971/72 – New York, hours 11B–12.

E-1: *The Structure of Being and its Universal Laws*, Class, 1973 – New York, hours 26–29.

Books by John W. Doorly:

Talks at the Oxford Summer School, 1949, Vol. I, pp. 49–140, Appendix: “Plan of the Gospel of Matthew.”

The translation of “St. Matthew” into Science

Biblical symbols	metaphysics	Science
1) genealogy	parent Mind	Mind
2) baptisms	purification	Spirit
3) temptations	identity	Soul
4) Sermon on the Mount	interpretation	Principle
5) healings	fullness of life	Life
6) What is man?	calculus of ideas	Truth
7) resurrection	fulfillment	Love
	} specific	} general
	} linear	} structural
	} interpretation	} creative

The formulation of phenomena into a scientific law

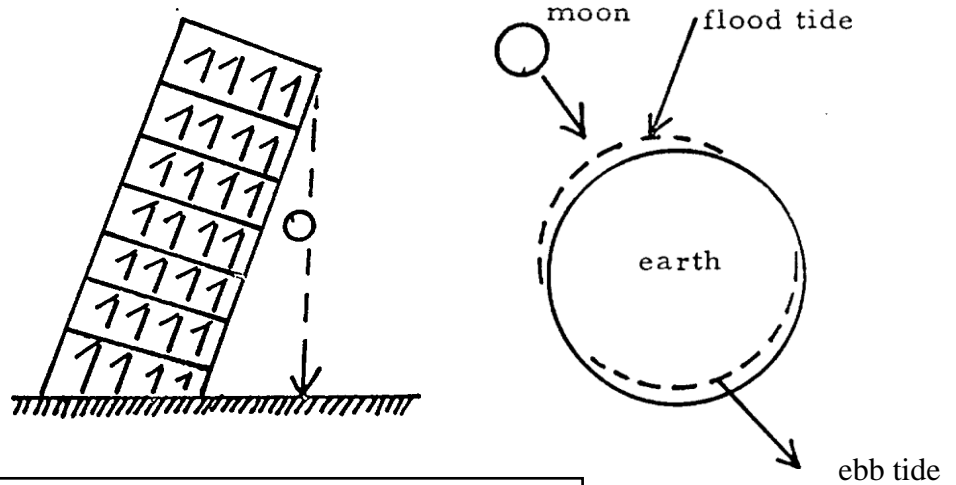

law:

$$F = g \frac{m_1 \cdot m_2}{r^2}$$

References to the previous two diagrams, “The translation of *St. Matthew* into Science” and “The formulation of phenomena into a scientific law”:

Recordings by Max Kappeler:

- B-2: *From Atomistic Thinking to Cybernetic Comprehensive Consciousness*, Class, 1970 – Ogunquit, (ME), hour 16
- D-4: *Divine Cybernetics and the Self-operating “Dimensional Laws” of the One Being, God*, Series of talks 1971/72 – New York, hour 12B.
- E-1: *The Structure of Being and its Universal Laws*, Class, 1973 – New York, hour 29B.
- G-2: *The Science of Being—As I See It Today*, Lecture, 1970 – London, England, (G-2), #7.

The law of interdependence in “The Christ”

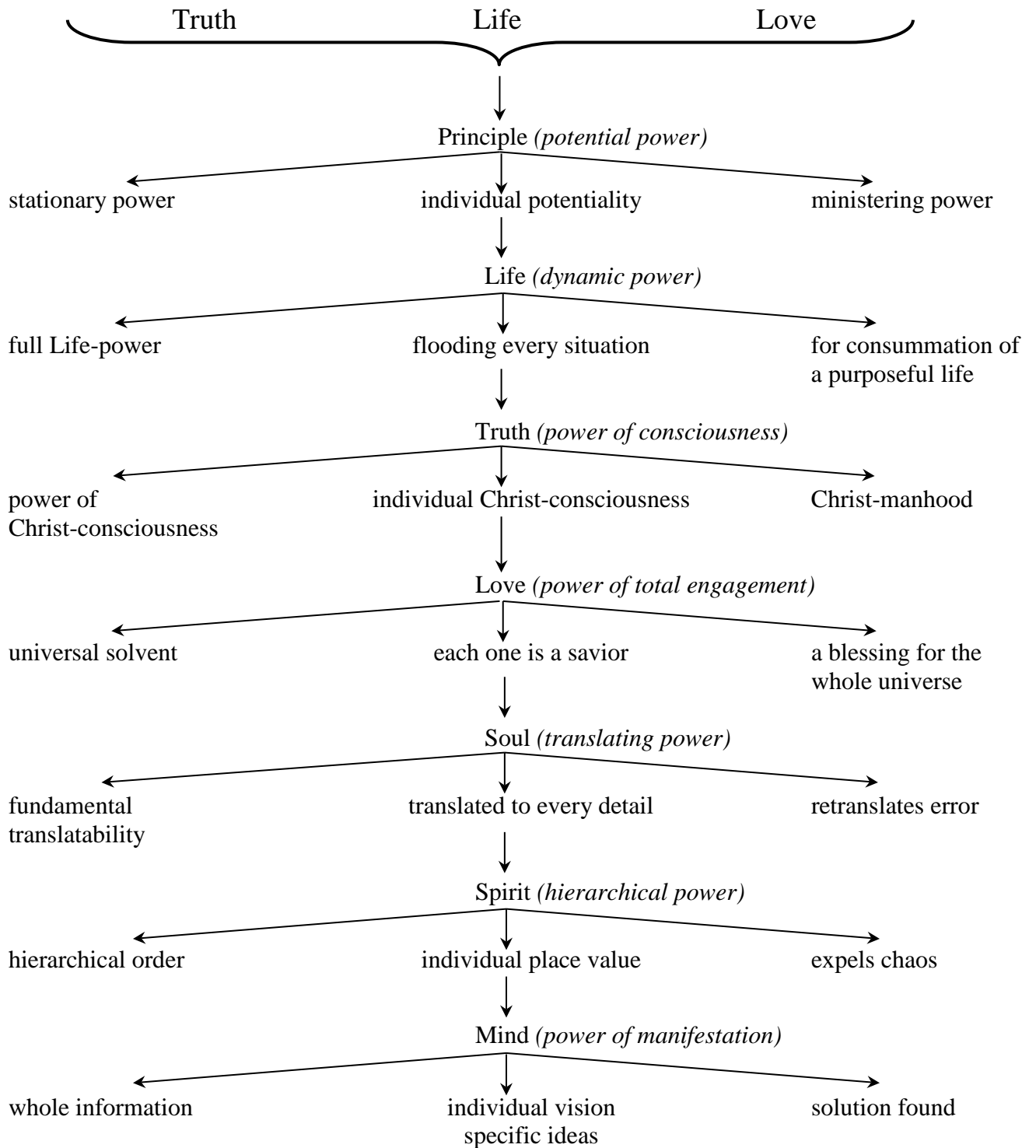

References to The law of interdependence in “The Christ”:

Books by John W. Doorly:

Talks at the Oxford Summer School, 1949, Vol. I, pp. 141–260, Appendix: “Plan of the Gospel of Mark.”

Recordings by Max Kappeler:

E-1: *The Structure of Being and its Universal Laws*, Class, 1973 – New York, hour 30.

The law of interdependence in “Christianity”

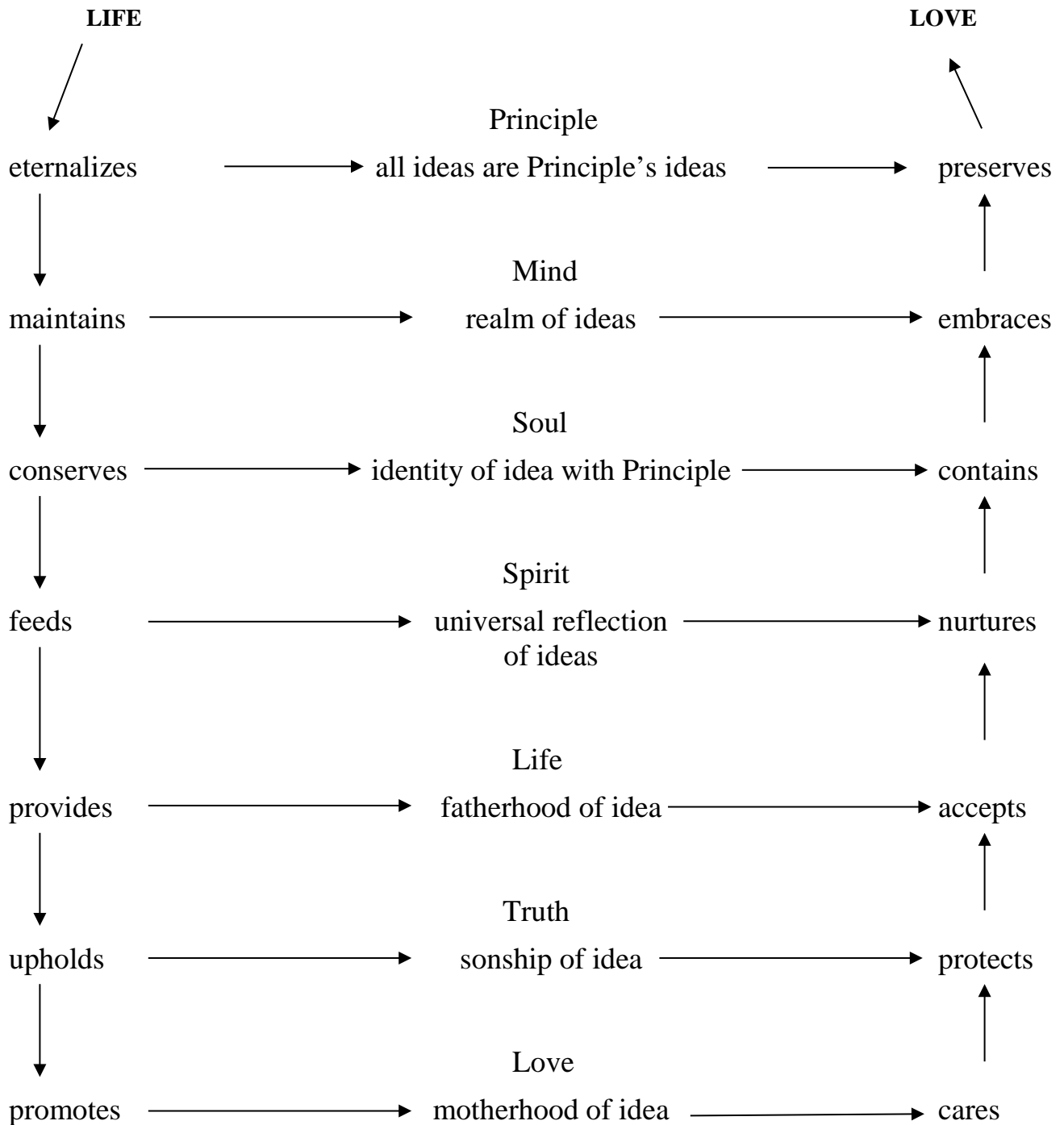

Recordings by Max Kappeler:

D-4: *Divine Cybernetics and the Self-operating "Dimensional Laws" of the One Being, God*, Series of talks 1971/72 – New York, hour 21. E-1: *The Structure of Being and its Universal Laws*, Class, 1973 – New York, hour 31.

The law of interdependence in “Science”

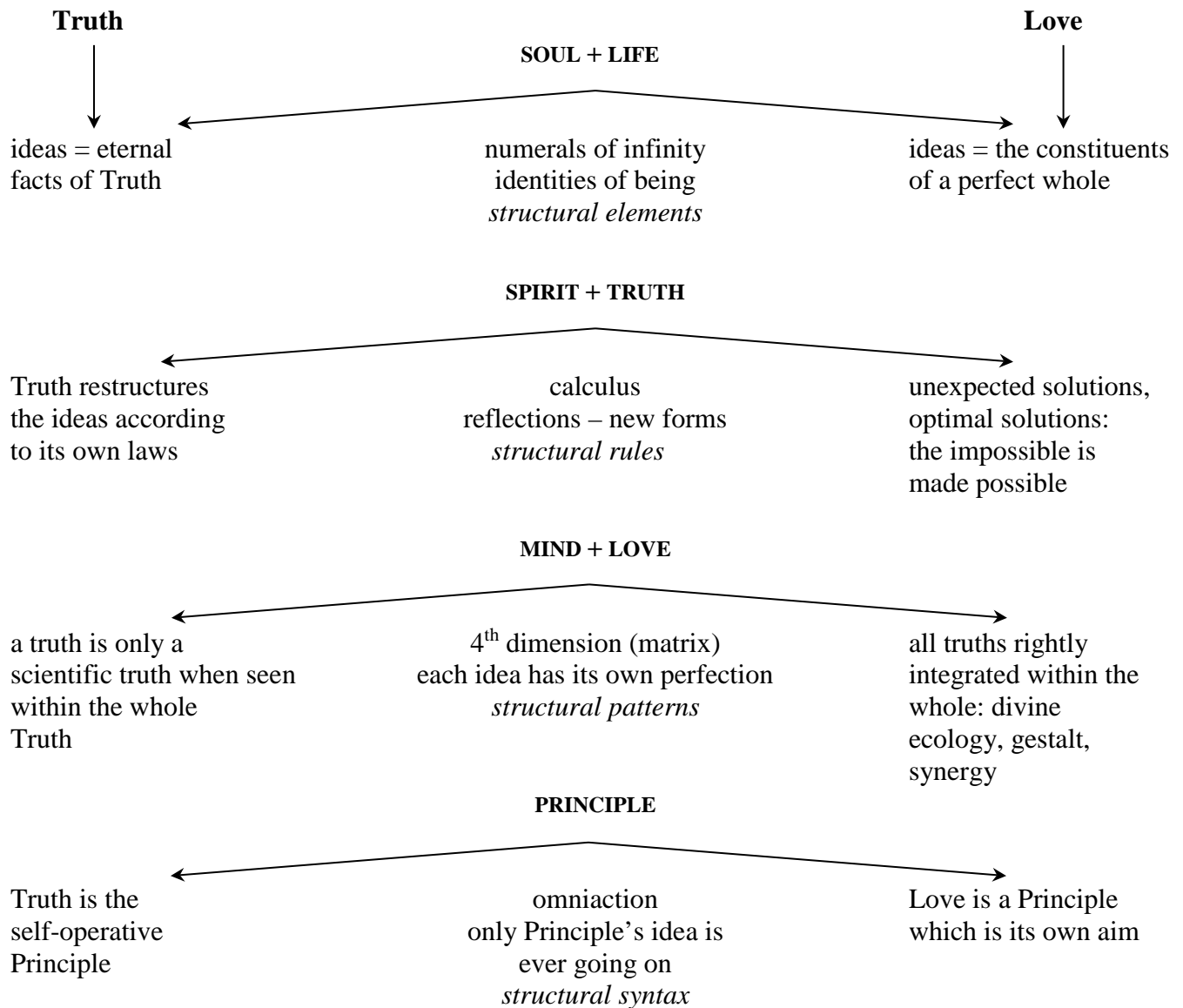

References:

Books by John W. Doorly:

Talks at the Oxford Summer School, 1949, Vol. II, pp. 131–273; Appendix: E-1: *The Structure of Being and its Universal Laws*, Class, 1973, New “Plan of the Gospel of John.”

Recordings by Max Kappeler:

E-1: *The Structure of Being and its Universal Laws*, Class, 1973, New York, hour 32.

The Science of the Bible

Equipped with a scientific, spiritual understanding of the divine system, John Doorly was able with its help to decode the Science of the Bible. Ever since the Bible has been in existence, hundreds of thousands, even millions of attempts have been made to interpret it. The interpretation changes according to the individual's subjective approach and inspiration. Are all free to interpret the Bible in any way they like, or is there a *fixed Principle* behind "the Scriptures, which grow in beauty and consistency from one grand root..." (S&H 341:6)? If there is, then this divine Principle interprets itself through and as the system of divine ideas which is inherent in the Principle itself. Knowing the system spiritually, John Doorly interpreted the Bible as a coherent exposition of the system of divine Principle.

We must therefore see the one super-important point, namely, that Doorly did not give just one more new interpretation of the Bible along side the already existing million ones; he did not give one more interpretation in the same category as all the others. Doorly's interpretation of the Bible is of an entirely new category—an interpretation from the standpoint of the one divine Principle interpreting itself through its own system. Mrs. Eddy supplied the key in the "Key to the Scriptures," namely in the chapters "Genesis" (with its main accent on the seven days of creation, indicating the seven synonyms for God) and "The Apocalypse" (with its main accent of the four sides of the holy city, the fourfold operational sense of Being.)

In investigating the Bible as a whole, Doorly first saw that the entire plan of the bible unfolded in thousand-year periods correlative to the order of the synonyms in the Word-order: Mind, Spirit, Soul, Principle, Life, leading in the sixth thousand-year period of Christian Science in Truth and to the coming millennium of Love. Also each book of the Bible shows a systematic layout. Some of the books unfold in the order of the seven synonyms as given in the Word-order, the Christ-order, the Christianity-order, or the Science-order; others may present their subject in the fourfold order of Word, Christ, Christianity, and Science, and so on. All this, therefore, shows that what Principle means to interpret is in the first place its own categories, its own structure, and not single incidents or aphorisms, not atomistic truths. This also naturally demands a completely new attitude on the student's part. It is not the interpretation of the parts which is of foremost interest, but the *structure* of the whole. The Principle of Christian Science is fundamentally holistic; the parts serve through their interrelations to bring out the whole.⁷

The structure of the Christian Science Textbook

The second major result that followed from John Doorly's exposition of what constitutes the divine system of Christian Science concerns "Science and Health" as such. In the 1950's it was seen that the Textbook has a very balanced coherent structure, so that it can be understood as a most remarkable exposition of the idea of Christian Science, in which from sentence to sentence, from paragraph to paragraph, from chapter to chapter, there flows a consistent unfoldment of the structure of Christian Science.

⁷ John W. Doorly published 13 books on the spiritual structure of the Bible obtainable through the John Doorly Trust, <http://johndoorlytrust.org/onlinebookstore.htm>.

In reviewing the whole development since 1910, one cannot help feeling that Mrs. Eddy's prophecy has found its fulfillment:

“I foresee and foresay that every advancing epoch of Truth will be characterized by a more spiritual apprehension of the Scriptures, that will show their marked consonance with the textbook ... Interpreting the Word in the “new tongue,” whereby the sick are healed, naturally evokes new paraphrase from the world of letters.” (Mis. 363:30)⁸

⁸ See Max Kappeler, *The Structure of the Christian Science Textbook—Our Way of Life*.

PART IV

Matrices

The Further Scientific Unfoldment to the Matrix Form

excerpt from the book,
When I think of John Doorly ... II, Introduction to the Matrix-Consciousness
Max Kappeler, ©2002

Contemplation of the fourfold order of Science led Doorly's understanding of the Science of Being further and further. The order of Science that includes the Science of Word, Christ, and Christianity is quite natural, because we know that in the one infinite Being every identity of being reflects every other identity. Every side of the Holy City reflects every other side. This results in $4 \times 4 = 16$ aspects. How can each side be defined by the seven synonyms for God? The order of Science symbolized by the candlestick has already provided the answer for the Science side. But what is the arrangement for the orders of Word, Christ, and Christianity? The Word also reflects Word, Christ, Christianity, and Science. The Christ and Christianity also reflect the other sides in a fourfold manner. Thereby, we have a 4×4 description of the four orders of the synonyms. Each of the four orders reflects the fourfold calculus. This raises the question of the transitions within each order that represent the steps from Word to Christ, from Christ to Christianity, and from Christianity to Science. Expressed somewhat differently: What is the essence of Word, Christ, Christianity, and Science in each of the synonym-orders? Doorly spent three years studying this question (1943-1945). He had to rely entirely on his excellent spiritual scientific sense that had become sharpened through his successful spiritual practice.

The question he asked was the following: How do Word, Christ, Christianity, and Science reflect each other in the Word-order, in the Christ-order, in the Christianity-order, and in the Science-order? At first, Doorly had no texts that could have provided an answer. Therefore, he had to listen to the divine Being, that is, to the spiritual meaning of the four synonym-orders. He spent hours and hours in the attempt to sense spiritually the form that was crystallizing. The answer did not come immediately or at once, but gradually, through spiritually directed attempts, so he was always ready to change his findings. Through his letters and those of his assistant at the time, Peggy M. Brook, I was able to follow his spiritual wrestling in achieving the correct result. In his book, *"The Pure Science of Christian Science"* (first edition 1946), he published the results of his research. At his last summer school in Oxford (1949), he made the last change based on the Gospel of Mark (see the second edition of 1949).

He presented his results to his students in the form of a table or chart (see Table I, p. 15). A mathematician listening to one of his lectures informed him that in scientific circles this type of table was called a "matrix." From then on, his students incorrectly referred to it as the "Doorly-Matrix." This is a wrong designation, for the matrix does not deal with John Doorly, but rather with the immortal one Being. It is much more the "matrix of immortality" according to the Textbook (205:5).

How is the term "*matrix*" defined? The word is derived from Latin and means "womb" or "topsoil." Webster defines "matrix" as: "A place or enveloping element within which something originates, takes form, or develops." This rather biologically based definition is very informative for us. Our matrix is an enclosing element that is also unfolded by the all-embracing One until it

takes on its complete form. The mathematical definition then provides the rules about how a matrix is built up. It is determined by columns (verticals) and rows or lines (horizontal). Each of the columns has a common denominator. The same applies to the rows. Where the columns and rows meet, there are points of intersection, each of which yields a new value. They are called the matrix elements.⁹

How are the $4 \times 4 = 16$ points of intersection explained by John Doorly?

⁹ For more detailed explanations of “matrix,” see Max Kappeler, *The Science of the Oneness of Being in the Christian Science Textbook* (Seattle: Kappeler Institute Publishing USA, 1983), pp. 255–256; Max Kappeler, *The Structure of the Christian Science Textbook—Our Way of Life, Vol. II: Interpretation of the Structure* (Seattle: Kappeler Institute Publishing USA, 2002); and Max Kappeler, *The Minor Prophets in the Light of Christian Science* (Seattle: Kappeler Institute Publishing USA, 1962), p. 17–21.

Matrix
(plural: matrixes or matrices)

matrix = womb, place of origin, cradle (= ‘the place in which anything is nurtured in its earlier stage’, Oxford Dictionary)
source, cause; grid, chessboard pattern

definitions:

The womb. A place or enveloping element within which something originates, takes form, or develops ... That which gives form, origin, or foundation to something enclosed or embedded in it (Webster).

A matrix is a schematic model or order. It has columns and rows or lines, which are constructed according to definite rules. The essential requirement is that all the elements in a column or in a row possess a common characteristic (Z. Dienes and E. Golding: *Mathematisches Denken und logische Spiele*, Herder 1966).

A rectangular array with systematic entries (Prof. Luft).

A matrix is an arrangement of values in lines and columns (Prof. Muller-Markus: *Wo die Welt nochals beginnt*, p. 279).

matrix elements:

A matrix is a rectangular arrangement of elements.

An element is a primary component, in the sense that it is not possible to divide an element and at the same time retain the properties which are relevant to the associative context. Elements form the constituent parts of magnitudes; their interrelation constitutes the structure of a magnitude. Matrices afford a more accessible general view of the functional interconnections of elements within a system (*Lexikon der Planung und Oranisation*, 1968).

purpose:

The word ‘matrix’ (denotes) any ability, habit, or skill, any pattern of ordered behaviour governed by a ‘code’ of fixed rules (Koestler: *The Act of Creation*).

A matrix is an aid to remembering the succession of operations. It needs few symbols, as each symbol acquires a special meaning according to its particular box within the grid.

Matrices themselves provide a very powerful condensed language in which complicated mathematical statements can be expressed simply (Evelyn Sharp: *The Parent's guide to the New Mathematics*).

A matrix is important for categorical, relational and structural thinking (Z. Dienes and E. Golding: *Mathematisches Denken und logische Spiele*, Herder 1966).

A matrix is a means to the most economic representation (*Mathematik-Duden für Lehrer*, Mannheim 1969).

A purely conceptual, not an observable, construct, superseding the last traces of physical detectability (Prof. Müller-Markus).

- aids structure recognition
- acts as a memory-support
- provides a cognizable over-all view
- is a steering mechanism

References for the “Matrix definitions”:

Books by Max Kappeler:

The Science of the Oneness of Being in the Christian Science Textbook, pp. 225–256.

The Minor Prophets in the Light of Christian Science, pp. 17–19.

Recordings by Max Kappeler:

C-4: *The Matrix of Science and Health: An overview*, Class, 1975 – Wilmington, (DE), hour 6.

C-6: *Exercises in Culturing Consciousness According to the Matrix of Science and Health*, Class 1976 – Ilkley, England, hours 1B–2A.

E-2: *The Matrix of Immortality: Code of divine laws*, Class 1974 – Wilmington, (DE), hours 1–4A, 20.

G-2: *The Science of Being—As I See It Today*, Max Kappeler, Lecture, 1970 – London, England, hours 4–7.

**The One Book
(THE WORD)**

Bible							Being
					<i>“Science and Health”</i>		
						The Model of Being	
Word		Christ		Christianity	Science		
MIND	SPIRIT	SOUL	PRINCIPLE	LIFE	TRUTH	LOVE	I AM
4000–3000 BC	3000–2000 BC	2000–1000 BC	1000–1 AD	1–1000 AD	1000–2000 AD	2000 AD –	
1 st 1000 years	2 nd 1000 years	3 rd 1000 years	4 th 1000 years	5 th 1000 years	6 th 1000 years	7 th 1000 years	
1 st day	2 nd day	3 rd day	4 th day	5 th day	6 th day	7 th day	8 th day
ADAM-ENOCH	NOAH-BABEL	ABRAHAM-JUDGES	SAMUEL-BIRTH JAMES	CHRIST JESUS	CHRIST SCIENCE	DIVINE SCIENCE	SCIENCE ITSELF
myths	legends, sagas	tribal history	revelation of the idea	unity of Jesus and idea	unity of Science and idea	God’s consciousness of itself (capitalized terms)	I AM
—	—	—	—	—	—	—	
mortal mind	matter	body	personal “I”	death	mortal consciousness	imperfection	

John Doorly’s Matrix
(*Word-matrix*)*

i j	The Word <i>(God’s self-declaration)</i>	The Christ <i>(the Christ-idea)</i>	Christianity <i>(God’s infinite self-reflection)</i>	Science <i>(God’s self-interpretation as Science)</i>
	<i>order</i>	<i>manifestation</i>	<i>reflection</i>	<i>numerals of infinity</i>
the Word <i>(creative)</i>	MIND SPIRIT SOUL	PRINCIPLE LIFE TRUTH LOVE	PRINCIPLE MIND SOUL SPIRIT	PRINCIPLE SOUL ——— LIFE
	<i>identity</i>	<i>translation</i>	<i>reality</i>	<i>infinite calculus</i>
the Christ <i>(Christ-selfhood)</i>	SOUL PRINCIPLE LIFE	TRUTH LOVE SOUL SPIRIT	SPIRIT LIFE TRUTH	SPIRIT ——— TRUTH
	<i>line</i>	<i>plane</i>	<i>space</i>	<i>fourth dimension</i>
CHRISTIANITY <i>(pure demonstration)</i>	LIFE TRUTH	LOVE SOUL SPIRIT MIND	MIND SOUL SPIRIT LIFE TRUTH LOVE	MIND ——— LOVE
	<i>omnipotence</i>	<i>omniscience</i>	<i>omnipresence</i>	<i>omni-action</i>
Science <i>(God-being)</i>	LIFE TRUTH LOVE	SOUL SPIRIT MIND	LIFE TRUTH LOVE	 PRINCIPLE

*This matrix, developed over the years by John W. Doorly, has since been further elaborated. Specifically, the “i” and “j” indices have been defined as shown in the parentheses; also the matrix as a whole is seen as the Word-matrix.

References: Books by John W. Doorly:

- The Pure Science of Christian Science* (London: The Foundational Book Company for the John W. Doorly Trust, 1949), 2nd edition, p. 53.
- Christian Science Practice* (London: The Foundational Book Company for the John W. Doorly Trust, 1949), p. 358.

The sixth day of creation
The diagonal of the Doorly-matrix

sixth day	WORD	CHRIST	CHRISTIANITY	SCIENCE
Word	$\begin{matrix} T \\ / \\ M, Sp \\ M \\ Sp \\ So \end{matrix}$ the order of God's primal creativity			
Christ		$\begin{matrix} T \\ / \\ So, P \\ T \\ Lo \\ So \\ Sp \end{matrix}$ the trans-lation of God to Man		
Christianity			$\begin{matrix} T \\ / \\ Li, T \\ M \\ So \\ Sp \\ Li \\ T \\ Lo \end{matrix}$ infinite space is peopled with ideas, all reflecting Li, T, Lo	
Science				$\begin{matrix} T \\ / \\ Lo \\ P \end{matrix}$ Principle includes all ideas in omni-action

References:

Books by Max Kappeler:

- The Bible in the Light of Christian Science*, Vol. I: Genesis, pp. 115–117, 120–123, 176–178.
- Epitomes for the Spiritually Structured Interpretation of the Christian Science Textbook*, 'Genesis,' p. 4.
- The Four Levels of Spiritual Consciousness: Science itself, divine Science, absolute Christian Science*, *Christian Science*, pp. 32–44 (the sixth day in its subtone and fourfold layout).

Recordings by Max Kappeler:

- C-1G: *CH. XV, Genesis, The Structure of the Christian Science Textbook—Our Way of Life*, Series of Talks: 1981, hour 14.
- D-1: *The 4 Levels of Science*, Series of Talks 1967/68 – London, England, hours 3–5.
- E-2: *The Matrix of Immortality: Code of divine laws*, Class 1974 – Wilmington, (DE), hours 3B, 11A.

The sixth-day diagonal of the matrix
The tones of the synonyms
(S&H 513:14–519:6)

Word/Word: The order of God's primal creativity (513:14–515:10)

Mind: God conceives all thoughts (513:17–21)

Spirit: God's thoughts unfold spiritual reality (513:26–514:9)

Soul: God's thoughts are defined through divine qualities (514:10–515:10)

Christ/Christ: The translation of God to man (515:11–517:24)

Truth: Truth translates itself to every idea through reflection (515:11–517:24)

Love: Love fashions all things in glorified quality (516:9–23)

Soul: Soul translates the ideal Truth to the point of ideal man and woman (516:27–517:14)

Spirit: The ideal is reflected in an infinitude of ideas (517:15–24)

Christianity/Christianity: Infinite space is peopled with ideas, all reflecting Life, Truth, and Love (517:25–518:23)

Life: Life multiplies the compound idea man (517:30–31)

Truth: Truth gives man dominion (517:31–518:2–4)

Love: Love makes this dominion universal (518:2–4)

Spirit: In the compound idea man, every idea reflects every other idea (518:13–17)

Soul: All ideas have identity of interest (518:17–19)

Mind: Every idea is the expression of the full manifestation of Mind (518:19–23)

Science/Science: Principle includes all ideas in omniaction (518:24–519:6)

References:

Books by Max Kappeler:

The Bible in the Light of Christian Science, Vol. I: Genesis, pp. 115–117, 120–123, 176–178.

Epitomes for the Spiritually Structured Interpretation of the Christian Science Textbook, 'Genesis,' p. 4.

The Four Levels of Spiritual Consciousness: Science itself, divine Science, absolute Christian Science, Christian Science, pp. 32–44 (the sixth day in its subtone and fourfold layout).

Recordings by Max Kappeler:

C-1G: *CH. XV, Genesis, The Structure of the Christian Science Textbook—Our Way of Life*, Series of Talks: 1981, hour 14.

D-1: *The 4 Levels of Science*, Series of Talks 1967/68 – London, England, hours 3–5.

E-2: *The Matrix of Immortality: Code of divine laws*, Class 1974 – Wilmington, (DE), hours 3B, 11A.

The Christ-matrix

	WORD <i>The mono-potency of God, good</i>	CHRIST <i>The manifestation of the Christ-likeness</i>	CHRISTIANITY <i>The preservation of the idea</i>	SCIENCE <i>The operation of the idea in its Principle</i>
Word <i>the divine purpose defined</i>	Hosea	Obadiah	Nahum	Haggai
Christ <i>the enforcement of the translation of two-ness into oneness</i>	Joel	Jonah	Habakkuk	Zechariah
Christianity <i>the disappearance of evil and the appearance of good rendered inescapable</i>	Amos	Micah	Zephaniah	Malachi
Science <i>the understanding of God</i>	Isaiah	Jeremiah	Ezekiel	Daniel

References:

Books by Max Kappeler:

The Minor Prophets in the Light of Christian Science (the entire book is devoted to this subject).

Recordings by Max Kappeler:

B-2: *From Atomistic Thinking to Cybernetic Comprehensive Consciousness*, Class, 1970 – Ogunq (ME), hours 11B–12.

E-2: *The Matrix of Immortality: Code of divine laws*, Class, 1974 – Wilmington, (DE), hours 16–2

F-1: *The Minor Prophets in the Light of Christian Science*, Class, 1962 – Los Angeles, (CA), 32 hours.

G-2: *The Science of Being—As I See It Today*, Lecture, 1970 – London, England, hours 6–7.

The Christianity-matrix
 = *the reciprocal relation of man to:*

	WORD <i>the grace of God</i>	CHRIST <i>the glory of Christ</i>	CHRISTIANITY <i>the idea of man's perfection</i>	SCIENCE <i>the Science of man</i>
Word <i>accepting the new faith</i>	Romans	Galatians	Colossians	Pastoral Epistles (I Timothy) (II Timothy) (Titus)
Christ <i>claiming the new faith</i>	I Corinthians	Ephesians	I Thessalonians	Philemon
Christianity <i>steadfastly abiding in the new faith</i>	II Corinthians	Philippians	II Thessalonians	Hebrews
Science <i>proving the new faith by living it</i>	James	I & II Peter	I, II, III John	Jude

References:

Books by Max Kappeler:

The Epistles in the Light of Christian Science (the entire book is devoted to this subject).

Recordings by Max Kappeler:

B-2: *From Atomistic Thinking to Cybernetic Comprehensive Consciousness*, Class, 1970 – Ogunquit, (ME), hours 12B–13A.

E-2: *The Matrix of Immortality: Code of divine laws*, Class, 1974 – Wilmington, (DE), hours 22–23.

F-2: *The Epistles in the Light of Christian Science*, Class, 1962 – Los Angeles, (CA), 31 hours.

G-2: *The Science of Being—As I See it Today*, Lecture, 1970 – London, England, hours 6–7.

The Matrix of Christian Science
(in Science and Health with Key to the Scriptures, by Mary Baker Eddy, Chapters I–XVI)

absolute standpoint (j) relative standpoint (i)	WORD revelation of God’s nature	CHRIST translation of God to idea	CHRISTIANITY the realm of ideas	SCIENCE Principle and idea is one
Word accepting the proposition	CHAPTER I <i>Prayer</i> revelation of God’s nature by accepting God’s nature in us	CHAPTER V <i>Animal Magnetism Unmasked</i> As we accept the Christ- translation, the ungodlike is translated back into its native nothingness	CHAPTER IX <i>Creation</i> As we accept the realm of ideas, the ideational universe reveals itself to us	CHAPTER XIII <i>Teaching Christian Science</i> By accepting our oneness with Principle, we are Principle- idea
Christ power of manifestation in spite of error	CHAPTER II <i>Atonement and Eucharist</i> God’s nature manifests itself in us in spite of the ungodlike in us	CHAPTER VI <i>Science, Theology, Medicine</i> The Christ-translation manifests itself by translating the false constituents into the true constituents of Being	CHAPTER X <i>Science of Being</i> The dynamic power of manifestation of ideas dissolves both latent and concrete error	CHAPTER XIV <i>Recapitulation</i> Principle-idea manifests itself as a calculus of ideas and corrects the calculus of human beliefs
Christianity exalted being	CHAPTER III <i>Marriage</i> God’s nature demonstrates itself in us as a higher humanhood	CHAPTER VII <i>Physiology</i> The Christ-translation translates mortals into immortals	CHAPTER XI <i>Some Objections Answered</i> The perfect reflection of ideas exalts a theoretical Christianity to a practical Christianity	CHAPTER XV <i>Genesis</i> In the oneness of Principle and idea, creation is exalted in its divine Principle
Science scientific understanding	CHAPTER IV <i>Christian Science vs. Spiritualism</i> God’s nature can be understood only by scientific methods of understanding	CHAPTER VIII <i>Footsteps of Truth</i> The Christ-translation translates an unscientific consciousness into a scientific consciousness	CHAPTER XII <i>Christian Science Practice</i> A scientific understanding of ideas heals	CHAPTER XVI <i>The Apocalypse</i> Scientific understanding recognizes that on all levels of existence, only the idea of Principle is ever going on

References for “The Matrix of Christian Science”

Books by Max Kappeler:

The Development of the Christian Science Idea and Practice ©2004, 2nd edition, pp. 8–18 (the development of the Science and structure of the textbook).

Epitomes for the Spiritually Structured Interpretation of the Christian Science Textbook (the entire book is presents an elaboration of this subject).

The Science of the Oneness of Being in the Christian Science Textbook, Appendix, Table 3, also pp. 263–267.

The Structure of the Christian Science Textbook (the entire book is devoted to explaining this subject).

‘*Stately Science Pauses Not*,’ (booklet), pp. 31–47.

When I think of John W. Doorly ... II—Introduction to the Matrix Consciousness, ©2002.

Recordings by Max Kappeler:

B-2: *From Atomistic Thinking to Cybernetic Comprehensive Consciousness*, Class, 1970 – Ogunquit, (ME), hours 13–14.

C-1: *The Structure of the Christian Science Textbook—Our Way of Life*, an extensive series spanning 30 years of talks
Series on the Textbook’s structure, covering both the structure of each chapter and the structure of the textbook as a whole (See Kappeler Institute Writings/Recordings Catalog).

C-2: *The Christian Science Textbook: A workshop on text-interpretation*, an analysis of the structure of the first five chapters to illustrate
Series the structural and scientific method of text-interpretation (See Kappeler Institute Writings/Recordings Catalog).

C-4: *The Matrix of ‘Science and Health’: An overview*, Class, 1975 – Wilmington, (DE), hours 7–24.

C-6: *Exercises in Structuring Consciousness According to the Matrix of ‘Science and Health,’* Class 1976 – Ilkley, England, 26 hours, especially hours 2B–9A.

E-2: *The Matrix of Immortality: Code of divine laws*, Class, 1974 – Wilmington, (DE), hours 11–16A.

M-20: *The Structure of the Christian Science Textbook: An overview*, 2 hours.

i-Matrix
from the i-index of
The Word, Christ, Christianity, and Science matrices

i-matrix	WORD	CHRIST	CHRISTIANITY	SCIENCE
Word	God's self-declaration	the Christ-idea	God's infinite self-reflection	God's self-interpretation
Christ	the mono-potency of God, good	the manifestation of the Christ-likeness	the preservation of the idea	the operation of idea in its Principle
Christianity	the grace of God	the glory of Christ	the idea of man's perfection	the Science of man
Science	revelation of God's nature	translation from God to man	the realm of ideas	Principle and idea is one

References:

Recordings by Max Kappeler:

E-2: *The Matrix of Immortality: Code of divine laws*, Class, 1974 – Wilmington, (DE), hour 24.

Books by Max Kappeler:

When I think of John W. Dooley ... II—Introduction to the Matrix-Consciousness, ©2003.

j-Matrix
from the j-index of
The Word, Christ, Christianity, and Science matrices

j-matrix	WORD	CHRIST	CHRISTIANITY	SCIENCE
Word	creative	divine purpose defined	accepting the new faith	scientific proposition
Christ	Christ-selfhood	the enforcement of retranslation	claiming the new faith brings transformation	power of manifestation
Christianity	individual demonstration	the disappearance of evil and the appearance of good	steadfastly abiding in the new faith brings victory	exaltation
Science	God-being	the understanding of God	proving the new faith by living it	scientific understanding

References:

Recordings by Max Kappeler:

E-2: *The Matrix of Immortality: Code of divine laws*, Class, 1974 – Wilmington, (DE), hour 24.

Books by Max Kappeler:

When I think of John W. Doorly...II—Introduction to the Matrix-Consciousness, ©2003.

The Matrix of the Oneness of Being
(in Science and Health with Key to the Scriptures, by Mary Baker Eddy, Chapters I–XVI)

divine stand- point (i) divine standpoint (j)	WORD <i>man’s oneness with God</i>	CHRIST <i>the expression of God’s oneness with man</i>	CHRISTIANITY <i>the one universe of ideas</i>	SCIENCE <i>integrated being</i>
Word <i>the fundamental proposition of oneness</i>	CHAPTER I <i>Prayer</i> the fundamental oneness of man with God	CHAPTER V <i>Animal Magnetism Unmasked</i> there is only one power of manifestation: God, good	CHAPTER IX <i>Creation</i> There is only one creation: the creation of ideas of the infinite One	CHAPTER XIII <i>Teaching Christian Science</i> Science can be gained only through scientific consciousness
Christ <i>Godlike manifestation</i>	CHAPTER II <i>Atonement and Eucharist</i> Man’s oneness with God is exemplified through the Godlike	CHAPTER VI <i>Science, Theology, Medicine</i> God and its manifestation is one	CHAPTER X <i>Science of Being</i> There is only one evolution: the spiritual	CHAPTER XIV <i>Recapitulation</i> Science and scientific metaphysics are one
Christianity <i>all-inclusiveness</i>	CHAPTER III <i>Marriage</i> man’s oneness with God’s universe	CHAPTER VII <i>Physiology</i> God is omnipotent in the realm of Truth and in the realm of belief	CHAPTER XI <i>Some Objections Answered</i> There is only one realm: the realm of the infinite reflection of ideas	CHAPTER XV <i>Genesis</i> being and becoming are one
Science <i>understanding – one conscious being</i>	CHAPTER IV <i>Christian Science vs. Spiritualism</i> Man’s understanding and God’s understanding are one	CHAPTER VIII <i>Footsteps of Truth</i> There is only one consciousness: the Christ-consciousness	CHAPTER XII <i>Christian Science Practice</i> Understanding and demonstration are one	CHAPTER XVI <i>The Apocalypse</i> oneness as such

References for “The Matrix of the Oneness of Being”

Books by Max Kappeler:

The Science of the Oneness of Being in the Christian Science Textbook, pp. Appendix, Table 2; the entire book is devoted to this subject.

Recordings by Max Kappeler:

- B-2: *From Atomistic Thinking to Cybernetic Comprehensive Consciousness*, Class, 1970 – Ogunquit, (ME), hours 21–22.
- C-3: *The 16 Aspects of Oneness in Science and Health*, Lecture, 1966, Princeton, (NJ).
- C-7: *The Science of Oneness in the Christian Science Textbook*, Class, 1977, Wilmington, (DE), hours 5–23.

Platform
(in Science and Health with Key to the Scriptures, by Mary Baker Eddy, 330: 11–340:29)

divine Science absolute Christian Science	WORD <i>the deific creator</i> <i>I–VIII</i>	CHRIST <i>the Christ-idea</i> <i>IX–XVI</i>	CHRISTIANITY <i>infinitely individualized spiritual reflection</i> <i>XVII–XXIV</i>	SCIENCE <i>scientific being</i> <i>XXV–XXXII</i>
Word <i>revelation of divine nature</i>	I + II God declared through the revelations of Mind	IX + X Christ is the true idea leading into all truth	XVII + XVIII Spirit creates infinitely individualized spiritually substantial things	XXV + XXVI with the Mind of God, perfection is seen
Christ <i>divine manifestation</i>	III + IV God expresses itself as an unlimited creation of good only	XI + XII the Christ expresses itself as the Godlike	XIX + XX Spirit evolves only immortal, spiritual reality	XXVII + XXVIII an understanding of the true idea of man brings God’s man to light
Christianity <i>universality</i>	V + VI God is All-in-all	XIII + XIV Christ comes at all times to all and blesses all	XXI + XXII the spiritual universe, including man, is the reflection of God	XXIX + XXX the ideal man is revealed through the destruction of all sin
Science <i>oneness of being</i>	VII + VIII God’s inner unity	XV + XVI the one Christ is eternal	XXIII + XXIV in the indivisible allness, God and man coexist	XXXI + XXXII understanding the allness and oneness of God demonstrates the unreality of evil and the reality of good

References:

Books by Max Kappeler:

Epitomes for the Spiritually Structured Interpretation of the Christian Science Textbook, pp. 2, 9–11.
The Structure of the Christian Science Textbook, pp. 101–105.

Recordings by Max Kappeler:

B-2: *From Atomistic Thinking to Cybernetic Comprehensive Consciousness*, Class, 1970, Ogunquit, (ME), hour 11A.
 C-1B III: *“The Platform, The Structure of the Christian Science Textbook—Our Way of Life*, 6 hours. This is also a reference for the following matrix, “Ideas Dissolve Beliefs.”
 E-2: *The Matrix of Immortality: Code of divine laws*, Class 1974 – Wilmington, (DE), hours 4B–5.

Ideas Dissolve Beliefs
(Chapter X, “Science of Being” in Science and Health)

Idea versus belief dissolves	Mind metaphysical basis versus material basis	Spirit spiritual reality versus material reality	Soul limitlessness versus limitations	Principle divine authority versus other authorities	Life immortal Life versus mortal life	Truth immortal consciousness versus mortal consciousness	Love oneness with God versus separation from God
Mind idea opposed to belief	Metaphysics, not matter is our basis	Like produces like; Mind does not produce matter	The divine Mind is unlimited; beliefs are limited	Man is the image of God; a material personality is not this image	Man as idea is immortal; mortals are not this idea	The origin of the real man is Mind; material man is illusive consciousness	Man is the manifestation of Mind, not of matter
Spirit idea is real, belief is unreal	Metaphysics is real; semi-metaphysics is unreal	Spirit is real; matter is unreal	Only the one God is real; there are not gods many	God and man are Principle and idea; they are not physical personalities	Spiritual life is real; material life is unreal	Spiritual man is real; material man is unreal	Man is born of Spirit; any other statement is illusive
Soul idea superior to belief, never “in” something	Metaphysics is above physics	Spirit explains away substance-matter	Soul is supreme over corporeality	The divine Principle is above human theories	Spiritual sense gains a higher level of existence	Spiritual consciousness must replace mortal consciousness	Man can never lose his high estate
Principle only idea has a divine Principle	Metaphysics bases itself on the Science of Mind	Spirit is the cause of substance	The one Ego is the Principle of man	The divine Principle governs the universe	Immortality is gained only through demonstration	A scientific consciousness has its foundation in Principle	Man can only work as Principle works
Life idea is exalted, eternal	Spiritualization of thought leads to eternal life	The substance of Spirit is eternal	Limitlessness is eternal	All that proceeds from Principle is eternal	Deathless life is gained through spiritual progression	Spiritual consciousness lifts us to our true individuality	Life demonstrates the immortality of man
Truth idea destroys false belief	Spiritual sense of truth annuls material truth	Spiritual consciousness annuls pantheistic beliefs	The true concept dispels the belief in limitations	Error yields to Truth	Error must be destroyed hourly	True consciousness dissolves false consciousness	The true forms of existence continue to exist undisturbed by mortal thought forms
Love idea is one with God; belief is nothing	All is the manifestation of Mind; there is no matter	Only reflections of good exist; matter is unknown	The unlimited knows no limitations	Harmony alone reigns; all conflicts are solved	When the last fault is destroyed, being is revealed and mortality is ended	True man exists always in perfection, beyond mortal illusions	Man is God’s man, never a mortal

Mind Matrix

(in *Science and Health with Key to the Scriptures*, by Mary Baker Eddy, Chapters I–XVI)

Mind	WORD all-Mind	CHRIST all-power of Mind	CHRISTIANITY allness of ideas	SCIENCE Mind and Mind-idea is one
Word Accepting the proposition	I. Prayer Mind is all-knowing	V. Animal Magnetism Unmasked Only the power of Mind operates, working out only good	IX. Creation Mind is the creator of all as idea	XIII. Teaching Christian Science The mind of the student must be in unity with the divine Mind
Christ the power of manifestation in spite of error	II. Atonement and Eucharist the power of Mind over material intelligence and matter	VI. Science, Theology, Medicine The all-power of Mind, not matter, is the all-redeeming power	X. Science of Being All is Mind and its infinite manifestation	XIV. Recapitulation All that is going on is Mind and Mind-idea
Christianity exalted being	III. Marriage Mind is superior to the human mind and matter	VII. Physiology To Mind and with Mind all is possible; Mind governs and controls all	XI. Some Objections Answered Before the unlimited divine Mind, all limited views must yield	XV. Genesis Mind constantly reveals itself as an ordered unfoldment of ideas
Science scientific understanding	IV. Christian Science vs. Spiritualism Mind alone possesses the faculty of knowing	VIII. Footsteps of Truth The understanding that there is only one Mind makes all harmonious and perfect	XII. Christian Science Practice The understanding that all is Mind heals	XVI. The Apocalypse The understanding of Mind uncovers the illusions of mortal mind

References:

Recordings by Max Kappeler:

B-2: *From Atomistic Thinking to Cybernetic Comprehensive Consciousness*, Max Kappeler, Class, 1970 – Ogunquit, (ME), hours 14B–15.

G-2: *The Science of Being—As I See It Today*, Max Kappeler, Lecture, 1970 – London, England, hour 5.

Books by Max Kappeler:

The Seven Synonyms for God, chapter 9, which also includes the matrices for the other synonyms. *Complete Compendium for the Study of Christian Science*, Appendix 8, p. 350, presents the tone of Principle in each chapter.

Super-Matrix

I Am	WORD <i>God's fundamental allness</i>	CHRIST <i>God's power of self-manifestation</i>	CHRISTIANITY <i>the All-in-all</i>	SCIENCE <i>the oneness of being</i>
Mind	all-Mind	all-power of Mind	allness of ideas	Mind and Mind-idea is one
Spirit	Spirit is the only	the onliness of Spirit	all is spiritual	Spirit and Spirit-idea is one
Soul	the infinite self-containment of Soul	the self-identification and infinite self-expression of Soul	the realm of Soul	Soul and Soul-idea is one
Principle	Principle is fundamental	Principle produces harmony	Principle demonstrates itself in everything	Principle and Principle-idea is one
Life	the isness of Life	dynamic eternality of Life	the Life of all life	Life and Life-idea is one
Truth	the self-affirmation of Truth	Truth's power of demonstration	the conscious being of Truth	Truth and Truth-idea is one
Love	the all-blessing of Love	Love's impact is wholly good	the all-blessed universe of Love	Love and Love-idea is one

References:

Books by Max Kappeler:

The Seven Synonyms for God, chapter 9, the comprehensive super-matrix.

The Spiritual Principle of Prayer

prayer on the level of divine Science	1. WORD all-Mind	2. CHRIST all-power of Mind	3. CHRISTIANITY allness of ideas	4. SCIENCE Mind and Mind-idea is one
a) Word <i>proposition of prayer-factor</i>	1a) the spiritual perfection of God	2a) the petitioner is not a person	3a) spiritual understanding of God	4a) the answer to prayer
b) Christ <i>expression of prayer-factor in consciousness</i>	1b) God's perfect self-expression	2b) only the divine in us can truly pray	3b) unselfed love	4b) letting God bless us in its own way
c) Christianity <i>outcome of prayer-factor as a perfect state or standpoint of prayer</i>	1c) God's perfection is already manifest as man	2c) praying to God from perfection	3c) being still and open to accept God's working	4c) the prayer of spiritual understanding meets every human need
d) Science <i>scientific oneness of prayer-factors</i>	1d) God's perfection is one with man's perfection	2d) that which prays and the answer to prayer is one	3d) accepting the working of God without resistance	5d) fundamentally, there is only one prayer

References:

Books by Max Kappeler:

The Science of Prayer, ©2003 revised edition.

The Matrix of Handling Evil

(in *Science and Health with Key to the Scriptures*, by Mary Baker Eddy, Chapters I–XVI)

	WORD <i>evil must be mastered</i>	CHRIST <i>the power of Truth destroys evil; evil has no power</i>	CHRISTIANITY <i>demonstrating the superiority of good over evil</i>	SCIENCE <i>by proving good, evil is disproved</i>
Word <i>Accepting the proposition</i>	I. Prayer the desire to be delivered from evil: deliver us from evil	V. Animal Magnetism Unmasked Science has the power to despoil evil, for evil is no power, action or law	IX. Creation Mortals must let themselves be used by good instead of by evil	XIII. Teaching Christian Science By resisting, exposing and denouncing evil, the nothingness of evil can be proved
Christ <i>the power of manifestation in spite of error</i>	II. Atonement and Eucharist the command to cast out evil	VI. Science, Theology, Medicine The power of Truth casts out evil	X. Science of Being The somethingness of good demonstrates the nothingness of evil	XIV. Recapitulation In the allness of God, good, evil has no place
Christianity <i>exalted being</i>	III. Marriage The good must have ascendancy over evil	VII. Physiology The only power of evil is to destroy itself	XI. Some Objections Answered denying that God either knows evil, made evil, or cooperates with evil	XV. Genesis Truth annihilates the belief in evil by reducing it to its nothingness
Science <i>scientific understanding</i>	IV. Christian Science vs. Spiritualism Understanding God, good, keeps evil in check	VIII. Footsteps of Truth Discernment of understanding good destroys the so-called power of evil	XII. Christian Science Practice Understanding the supremacy of good causes evil to disappear	XVI. The Apocalypse By understanding God, good, the nothingness of evil is made manifest

References to “The Matrix of Handling Evil”:

Recordings by Max Kappeler:

- A-6II: Syllabus II, 1977, hours 22–23.
- B-2: *From Atomistic Thinking to Cybernetic Comprehensive Consciousness*, Class, 1970 – Ogunquit, (ME), hours 15B–16, 24.
- B-3 *Christian Science Practice: Based on the Science of divine revelation*, Class 1976, Wilmington, (DE), hours 3–8.
- C-1AN: *CH. V, Animal Magnetism Unmasked, The Structure of the Christian Science Textbook—Our Way of Life*, hours 2–4, 7B–8.
- C-6: *Exercises in Culturing Consciousness According to the Matrix of Science and Health*, Class 1976 – Ilkley, England, hours 10–11.
- G-2: *The Science of Being—As I See It Today*, Max Kappeler, Lecture, 1970 – London, England, hour 5.
- X-5 *The Problem of Handling Evil*, 6 hours from B-3 (#3–8).

Books by Max Kappeler:

- Animal Magnetism — Unmasked*, pp. 47–81.
- Notes on Handling Evil* (booklet).

Books by John Doorly:

- Christian Science Practice*, pp. 328–329, 344–346, 349–355.
- Talks on the Science of the Bible*, #70 “blue-book,” pp. 15–20.111
- Talks on the Science of the Bible*, Vol. VI “red-book,” pp. 108–110, 231–232, 289–290.
- Talks on the Science of the Bible*, Vol. VII “red-book,” pp. 13–15, 16–19, 42, 83–85, 283–289.

The first part of the document discusses the importance of maintaining accurate records of all transactions. This includes not only sales and purchases but also any other financial activities that may occur. The second part of the document provides a detailed breakdown of the company's income and expenses for the year. This includes a list of all revenue sources and a corresponding list of all expenses. The third part of the document discusses the company's overall financial performance and provides a summary of the key findings. This includes a comparison of the company's performance to industry benchmarks and a discussion of the factors that have contributed to the company's success. The fourth part of the document provides a detailed analysis of the company's cash flow and provides a summary of the key findings. This includes a comparison of the company's cash flow to industry benchmarks and a discussion of the factors that have contributed to the company's success. The fifth part of the document provides a detailed analysis of the company's debt and provides a summary of the key findings. This includes a comparison of the company's debt to industry benchmarks and a discussion of the factors that have contributed to the company's success. The sixth part of the document provides a detailed analysis of the company's equity and provides a summary of the key findings. This includes a comparison of the company's equity to industry benchmarks and a discussion of the factors that have contributed to the company's success. The seventh part of the document provides a detailed analysis of the company's overall financial position and provides a summary of the key findings. This includes a comparison of the company's overall financial position to industry benchmarks and a discussion of the factors that have contributed to the company's success. The eighth part of the document provides a detailed analysis of the company's future prospects and provides a summary of the key findings. This includes a comparison of the company's future prospects to industry benchmarks and a discussion of the factors that have contributed to the company's success. The ninth part of the document provides a detailed analysis of the company's risk management and provides a summary of the key findings. This includes a comparison of the company's risk management to industry benchmarks and a discussion of the factors that have contributed to the company's success. The tenth part of the document provides a detailed analysis of the company's compliance and provides a summary of the key findings. This includes a comparison of the company's compliance to industry benchmarks and a discussion of the factors that have contributed to the company's success.